



OPERATION MANUAL

TEMPERATURE-CONTROLLED SOLDERING STATION

RX-701AS/711AS

CE	model	RX-701AS/22, RX-701AS/23, RX-701AS/24
		RX-711AS/22, RX-711AS/23, RX-711AS/24



Thank you for buying the **goot** Soldering Station. Read this Operation Manual before using your soldering station.

NOTE This is a common operation manual for RX-701AS & RX-711AS. Each model number is mentioned in the text. Be sure to read properly for your model.

1. SAFETY MARK DEFINITIONS	2
2. FOR SAFE OPERATION	2
3. PACKAGE CONTENTS / NAME OF PARTS	4
4. OPERATION	5
5. MAINTENANCE	7
6. IN THE EVENT OF FAILURE	9
7. SPECIFICATIONS	9
8. REPLACEMENT TIP	10
9. PARTS LIST	11
10. SOLDERING IRON STAND ST-27 INSTRUCTIONS.....	12

TAIYO ELECTRIC IND.CO.,LTD.

www.goot.co.jp E-mail: info@goot.co.jp

2-16-8 Yamate, Fukuyama, Hiroshima 720-0092 JAPAN

1. SAFETY MARK DEFINITIONS

In this manual, the following safety marks are used.



WARNING

Failure to obey a safety warning could result in serious injury or death to yourself or to others, or in physical damage



CAUTION

Failure to obey a safety warning could result in injury to yourself or to others, or in physical damage.



NOTE A note or word of advice.

2. FOR SAFE OPERATION

1. Do not use in dangerous environments. Never use it in damp, humid or wet locations (including outside), or near flammable substances.
2. Keep children and bystanders away from the unit.
3. Turn off the power when not in use.
4. This soldering station is an electrical tool used to solder parts and melt solder. Do not use the soldering station for any purpose not intended.
For example : the soldering station should never be used to warm water or other liquids.
5. Wear proper apparel and safety glasses.
6. Connect to a correct AC power supply. Do not use with any power voltage other than the indicated voltage.
7. If the power cord is damaged, stop using immediately and turn off the power. Return to the distributor for replacement.
8. Be sure to use the ST-27 soldering iron stand included with this soldering station. Other soldering iron stands may melt the parts of this unit.

9. Plug the machine into a grounded 3-prong plug. Make sure that the machine must be grounded at all times to prevent electrical shocks and static electricity.
10. The soldering iron is not intended for use by persons (including children) with reduced physical, sensory or mental capabilities, or lack of experience and knowledge, unless they have been given supervision or instruction concerning use of the appliance by a person responsible for their safety. Children should be supervised to ensure that they do not play with the appliance.
11. Do not disassemble the control unit.
12. This appliance can be used by children aged from 8 years and above and persons with reduced physical, sensory or mental capabilities or lack of experience and knowledge if they have been given supervision or instruction concerning use of the appliance in a safe way and understand the hazards involved.
13. Cleaning and user maintenance shall not be made by children without supervision.



WARNING

This soldering handle must be placed on its stand when not in use

3. PACKAGE CONTENTS / NAMES OF PARTS

■ Control Box

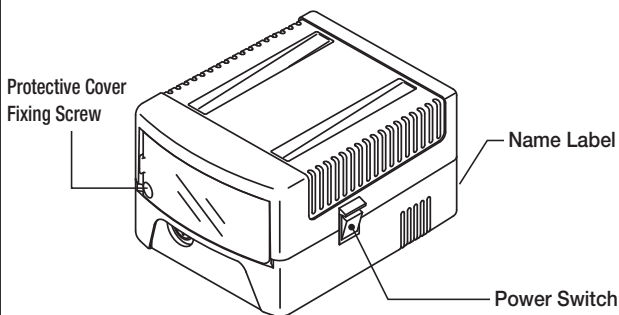
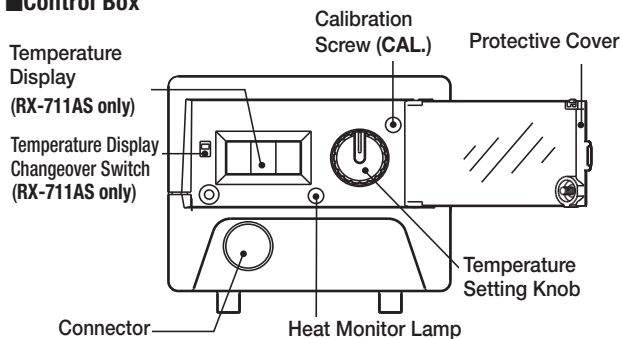

■ Soldering Iron

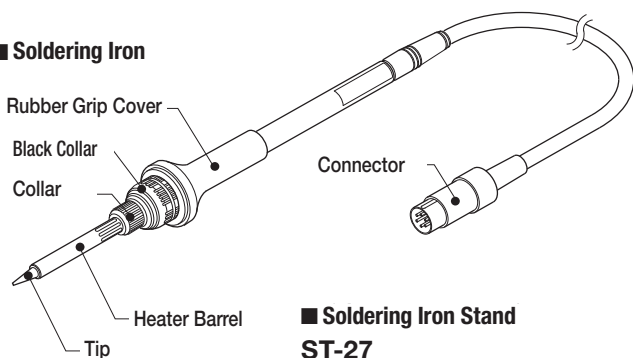

■ Soldering Iron Stand ST-27

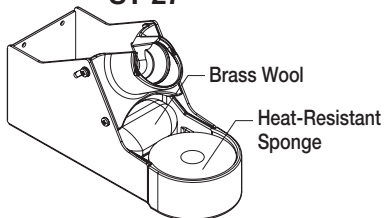

4. OPERATION



WARNING

To prevent fire, do not use the soldering station near flammable substances. Failure to obey this warning could result in serious injury or death to yourself or to others.

1. Always place the machine and the soldering iron stand on a stable worktable in a well-ventilated area.
2. Connect the soldering iron to the control box. Confirm the orientation of the plug.
3. Put the soldering iron into the soldering stand firmly.
4. Check that the power switch on the control box is OFF (O side), and then plug in the control box.
5. Loosen the fixing-screw at the bottom left of the protective cover by Phillips-head screwdriver. Open the protective cover for temperature setting.

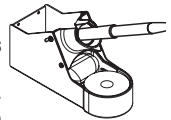

A. RX-701AS only

1. Set the desired temperature using the Temperature Setting Knob.
2. Switch the power switch ON (to I side). The Heat Monitor Lamp will light up and the heater will start heating up. When the Heat Monitor Lamp flashes, the soldering station is ready to use.

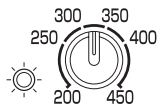
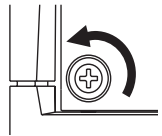

NOTE

It may take time to completely stabilize the temperature. When accurate temperature control is required, we recommend waiting 2 minutes after device is switched on.

B. RX-711AS only

1. Switch the Temperature Display Changeover Switch (at the left of the front panel) to SET. Display shows setting temperature.
2. Switch the power switch ON (to I side). The Heat Monitor Lamp will light up and the heater will start heating up. The temperature display initially shows "999" for approx. 10 seconds, then shows setting temperature.
3. Set the desired temperature using the Temperature Setting Knob.

MEAS.



SET

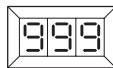

4. Switch the Temperature Display Changeover Switch (at the left of the front panel) to MEAS. Display shows the actual tip temperature. When the Heat Monitor Lamp flashes, the soldering station is ready to use. However if the unit is switched ON again with 1 hour of being switched OFF, and the displayed number is close to "000", then it is showing the actual tip temperature.

MEAS.



SET



CAUTION

Never set the temperature over 500°C. Your soldering station could be damaged.



NOTE

Approx. 2°C difference between the SET and MEAS display may occur. In this case, there is no need to adjust the tip temperature (by knob) on MEAS display. The factory default tip temperature is set on SET display.



NOTE

When the temperature display is set to MEAS, there is a temperature fluctuation from 2°C to 3°C.



NOTE

MEAS display has a 10-second delay. If the temperature changes for less than 10 seconds, the display will not change. Ex.) If the tip is rested on a wet sponge, temperature display will continue to show set temperature (eg. 480°C) for approx. 10 seconds. Then it will start dropping. During those 10 seconds, the temperature-control circuit is working to recover the set temperature.



NOTE

It may take time to completely stabilize the temperature. When accurate temperature control is required, we recommend waiting 2 minutes after device is switched on.

5. After setting the temperature, close the protective cover and tighten the fixing-screw at bottom left with a Phillips-head screwdriver.
6. Remove the solder scrap on the iron tip regularly with the wet sponge of the soldering iron stand.

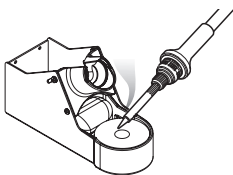

WARNING

Turn off and unplug the soldering station if there is a burning smell, overheating, or if the plastic parts deform. Do not use it again and contact your nearest distributor. Continued use could result in serious personal injury or damage.



WARNING

Never touch the heater barrel, collar, or adapter, to prevent personal injury or burning yourself.



CAUTION

Do not hit or drop the tip or the heater, to avoid deformation or breakage. The tip life may be decreased when using lead-free solder.

5. MAINTENANCE



WARNING

Turn off the main power switch (to 0 side), and unplug the power cord before maintenance. And be sure that the tip is cooled down. Failure to obey this warning could result in electric shock or serious injury.



CAUTION

Use only genuine goot replacement parts for maintenance. The use of any other parts may be hazardous and cause damage to the unit.

5-1 REPLACEMENT OF TIP

1. Remove the collar by turning it in a counter-clockwise direction.
2. Pull out the heater barrel, then pull out the tip from the heater.
3. Reassemble with new tip, reversing these steps.

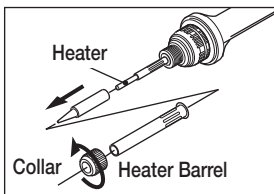

NOTE

To prevent seizing, regularly pull out the tip from the heater and remove the oxidized dross inside.

5-2 REPLACEMENT OF HEATER

1. Remove the Collar by turning it in a counter-clockwise direction.
2. Pull out the Heater Barrel, then pull out the tip & Spacer from the heater.
3. Remove the Black Collar by turning it in a counter-clockwise direction.

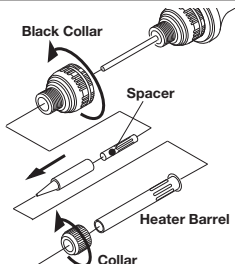

4. Disconnect the Earth Connector from the Earth Pin; remove the sleeve; remove the entire assembly, pulling on the Earth Collar.

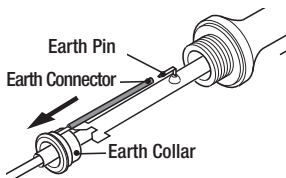

5. Desolder the 3 locations of pins for the heater. Remove the heater from the PCB.

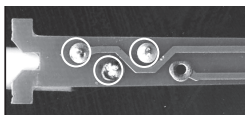

6. Solder the new heater to the PCB. Cut out the extra heater lead wire 3mm or less from the PCB.

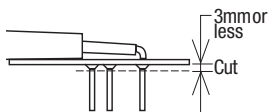
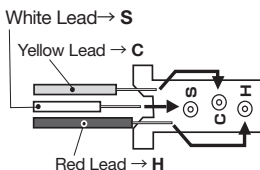

7. Next, about the PCB slot orientation. The PCB slots are offset from center. The longer arc should be up. The shorter arc should be down. The Earth Pin should be down.

PCB Slot Orientation

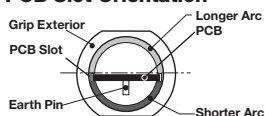

Ensure the PCB is inserted correctly according to the above diagram.

8. Reassemble, reversing these steps.

5-3 TEMPERATURE CALIBRATION

(Tip thermometer required)

A. RX-701AS only

1. Set the desired temperature using the Temperature Setting Knob.
2. While measuring the tip temperature with a tip thermometer, adjust the CAL (Calibration Screw) with Flat-head screwdriver to bring the measured temperature to the desired temperature scale. The tip temperature increases when the CAL is turned clockwise, and it decreases when the CAL is turned counter-clockwise.

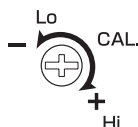

B. RX-711AS only

1. Switch the Temperature Display Changeover Switch (at the left of the front panel) to SET.
2. Set the desired temperature using the Temperature Setting Knob.
3. While measuring the tip temperature with a tip thermometer, adjust the CAL (Calibration Screw) with Flat-head screwdriver to bring the measured temperature to the desired temperature scale. The tip temperature increases when the CAL is turned clockwise, and it decreases when the CAL is turned counter-clockwise.

MEAS.



SET

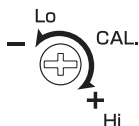

**NOTE**

The factory default tip temperature is 350°C. The thermal difference between the actual measured tip temperature and the displayed temperature is in the range of +/-10°C at 200°C, and 450°C(RX-701AS only) or 480°C(RX-711AS only). Tip thermometer readings may vary slightly.

**NOTE**

To prevent any damage to soldering station or other objects, make sure to calibrate the tip temperature after replacement of the tip or heater. If you do not have a tip thermometer, or you are unable to calibrate, please contact your nearest distributor.

5-4 PLASTIC COMPONENT CARE

Do not allow gasoline, petroleum-based, permeable oil to contact any plastic parts. It may damage the machine or the components. Use a clean cloth to wipe the machine.

6. IN THE EVENT OF FAILURE

Proceed with the following steps if you have any problems.

1. Check that the power cord is not damaged. If you notice any signs of damage, please contact your distributor.
2. If the cord is fine, use the below troubleshooting guide.
3. Turn off and unplug the soldering station if there is a burning smell, overheating, or if the plastic parts deform. Please contact your distributor.

PROBLEM	REASON	ACTION
Power does not turn ON.	Power cord unplugged?	Connect it properly.
	Power switch is OFF (0 side).	Turn switch ON (to I).
	Power cord damaged?	Contact distributor.
	Fuse blown out?	Contact distributor.
Heater does not heat up.	Connector loose or disconnected?	Connect it properly.
	Heater damaged?	Replace the heater (See 6-2).
	Soldering-iron cord damaged?	Replace the soldering iron.
Other problems	PCB may be broken, contact to distributor.	

4. If the machine is dropped, be sure to check the above troubleshooting guide. If you notice any signs of damage, do not use it, and please contact your distributor.

7. SPECIFICATIONS

MODEL	RX-701AS	RX-711AS
Voltage	110V, 120V, 130V, 220V, 230V, 240V AC 50/60Hz	
Power Consumption	65W	
Output Voltage	24V	
Temperature Setting Range	200-450°C (392-842°F)	200-480°C (392-896°F)
Insulation Resistance	Over 100MΩ	
Dimensions	Control Box	146(L) × 115(W) × 98(H)mm
	Soldering Iron	197mm (w/o cord)
Weight	Control Box	1.5kg (w/o cord)
	Soldering Iron	44g (w/o cord)
Connecting Cord Length	1.2m	
Power Cord Length	3-prong cord 1.5m	
Leak Voltage	Less than 2mV	
Ground/Earth Resistance	Less than 2Ω	
Accessories	Soldering Iron Stand: ST-27 , Tip: PX-60RT-B	

8. REPLACEMENT TIP

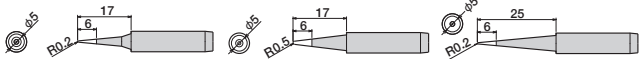

PX-60RT-SB

PX-60RT-B

PX-60RT-LB

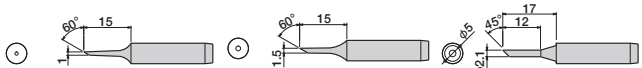

PX-60RT-1C

PX-60RT-1.5C

PX-60RT-2C

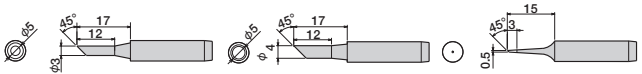

PX-60RT-3C

PX-60RT-4C

PX-60RT-0.5CR

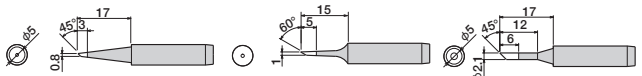

PX-60RT-0.8CR

PX-60RT-1CR

PX-60RT-2CR

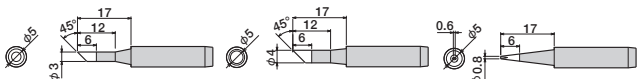

PX-60RT-3CR

PX-60RT-4CR

PX-60RT-0.8D

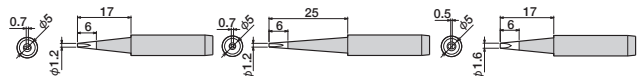

PX-60RT-1.2D

PX-60RT-1.2LD

PX-60RT-1.6D

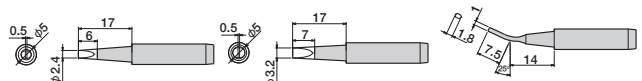

PX-60RT-2.4D

PX-60RT-3.2D

PX-60RT-1.8H

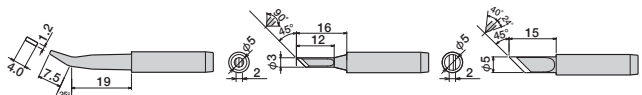

PX-60RT-H

PX-60RT-3K

PX-60RT-5K

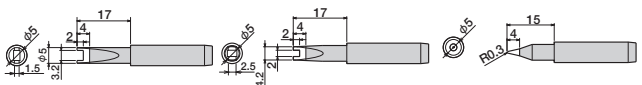

PX-60RT-R

PX-60RT-RT

PX-60RT-S4

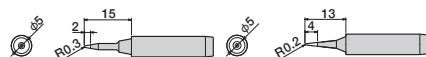

PX-60RT-SB2

PX-60RT-SI

9. PARTS LIST

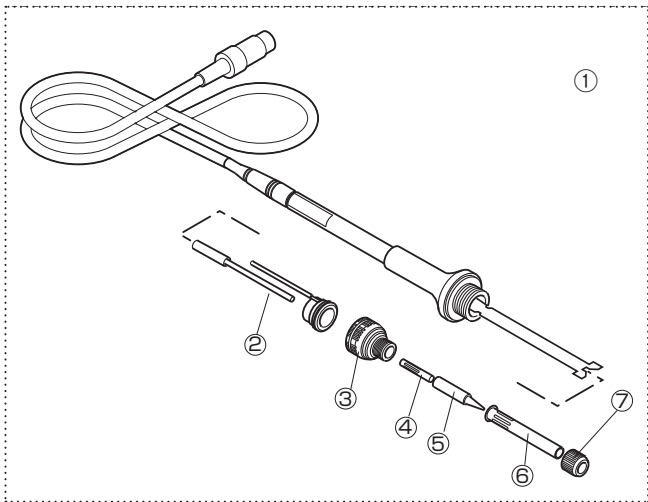

NO.	Parts Name	Code	Note
①	Soldering Iron Unit	A0883AF00	RX-72GAS
②	Heater	B0882AH00	RX-72H
③	Black Collar	A0880HW00	RX-72GASAD
④	Spacer	A0880HS00	RX-72SS
⑤	Tip	B0672AB00	PX-60RT-B
⑥	Heater Barrel	A0880HP00	RX-72HP
⑦	Collar	B1362AJ00	TQ-77NUT

SOLDERING IRON STAND

ST-27

INSTRUCTIONS



WARNING

- High temperatures. Handle with care.
- To avoid injury, do not touch the metal part of the stand.
- To prevent fire, do not use the ST-27 near flammable substances.



CAUTION

- Always place the stand on a stable worktable, or other stable location, to prevent injury or accident from dropping it.
- To avoid splattering solder scrap, do not swipe the tip of the iron across the brass wool. This is dangerous.
- To prevent fire or personal injury, be sure that the stand has cooled sufficiently before storing it.

INSTRUCTION FOR USE

Rub the soldering-iron tip on the moistened sponge.

Use the hole of the sponge for better cleaning.

Alternatively, push the soldering-iron tip in and out of the brass wool a few times. Stab, not swipe.



NOTE

•To avoid rust, do not pour water on the brass wool. •Sponge tray and holding flange (of the front opening) are made of phenol. Be aware that extended tip-contact may result in their deterioration. •Remove the collected solder scrap regularly.

NAMES OF PARTS / REPLACEMENT PARTS

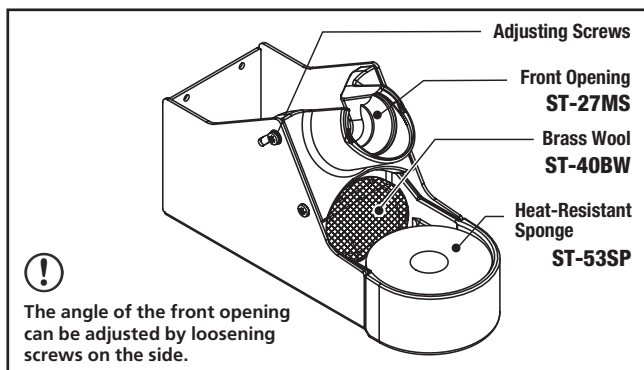

REPLACEMENT PARTS

☐ Heat-Resistant Sponge / ST-53SP

☐ Front Opening (with adjusting screws)/ ST-27MS

☐ Brass Wool (2balls) / ST-40BW

DIMENSIONS

Size	72(W) × 106(H) × 178(D)mm
Weight	485g

