

uArm Swift Pro

Quick Starter Guide
V1.0.15

Contents

SAFETY INSTRUCTIONS	3
PRODUCT OVERVIEW	4
1.Reference frame.....	4
2.Buttons & indicator lights	5
3.Extension description	6
HARDWARE INSTALLATION.....	7
1. Suction cup (default)	7
2. Laser	8
3. 3D Printing	11
4. Swift Gripper	15
6. Seed Grove Modules	18
7. OpenMV Module.....	20
OFFLINE LEARNING MODE	29
SOFTWARE: UARM STUDIO (WIN/MAC)	30
1.Download uArm Studio	30
2. Device Connection	30
3. Drawing/Laser Engraving.....	31
4.3D Printing.....	33
6.Blockly: Visual Programming	37
UARM COMMUNITY	39
RELEASE NOTE	39

Safety Instructions

1. Please don't put your hands between the arms when uArm is moving.
2. Please use the official power supply for safety reasons.
3. Please clear a space for uArm, in case of knocking down anything.

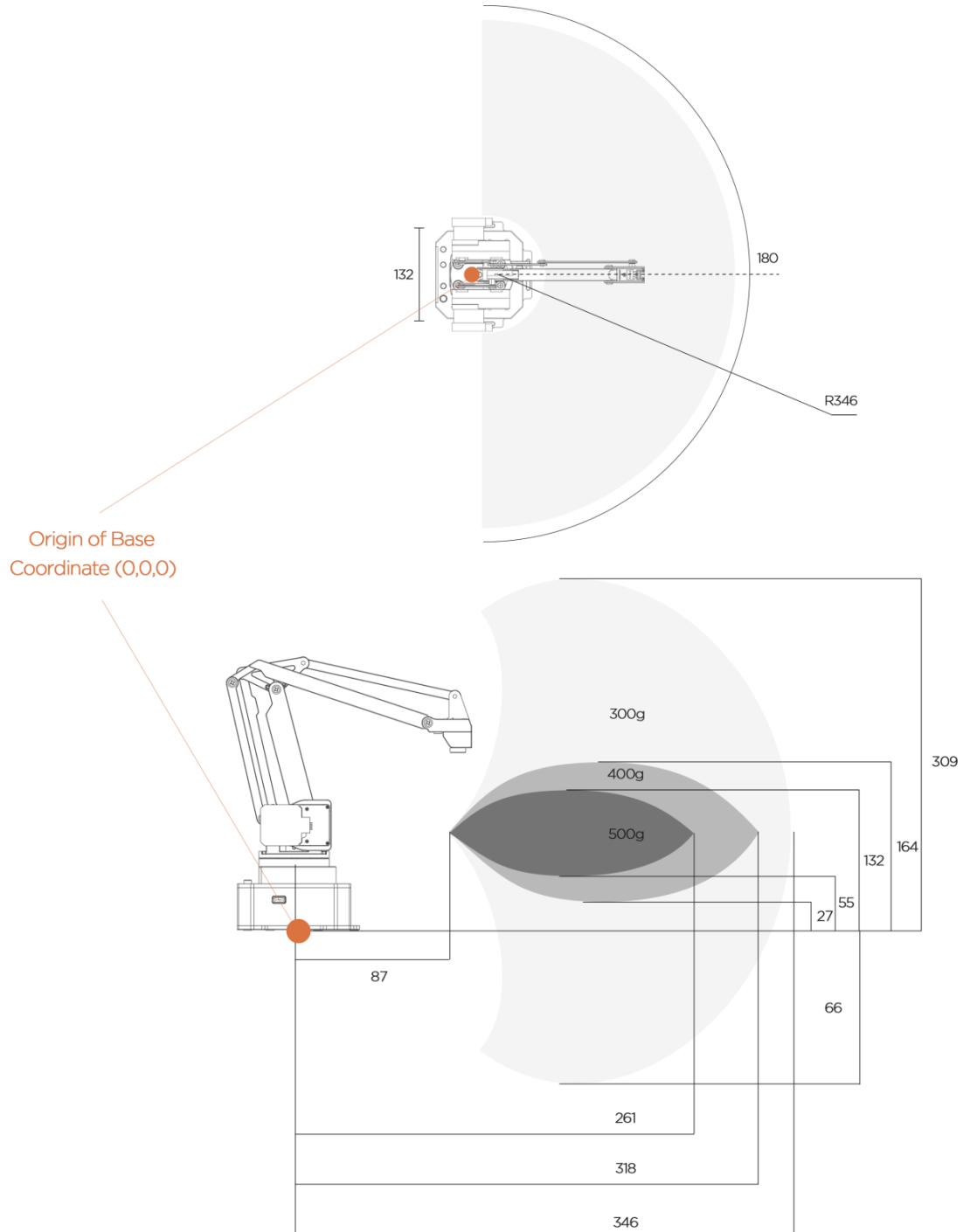

Product Overview

1. Reference Frame

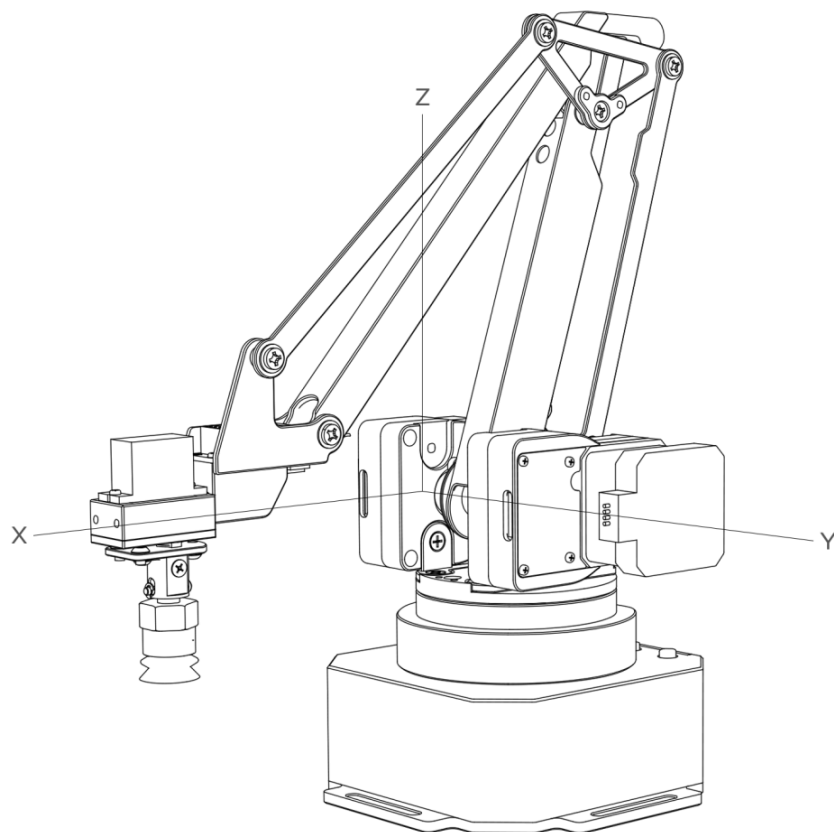
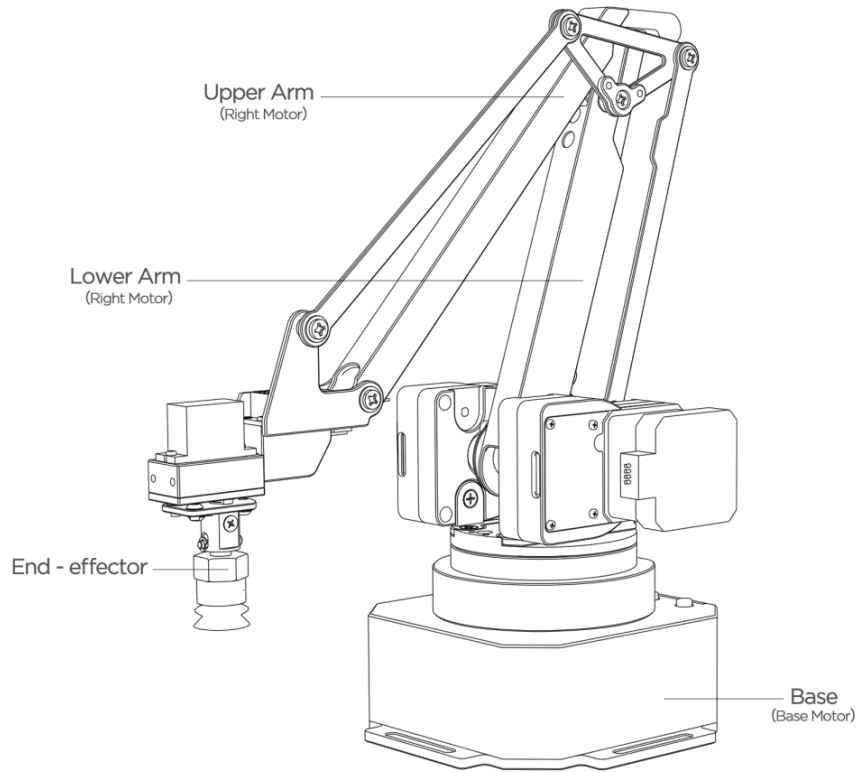

2. Buttons & Indicator Lights

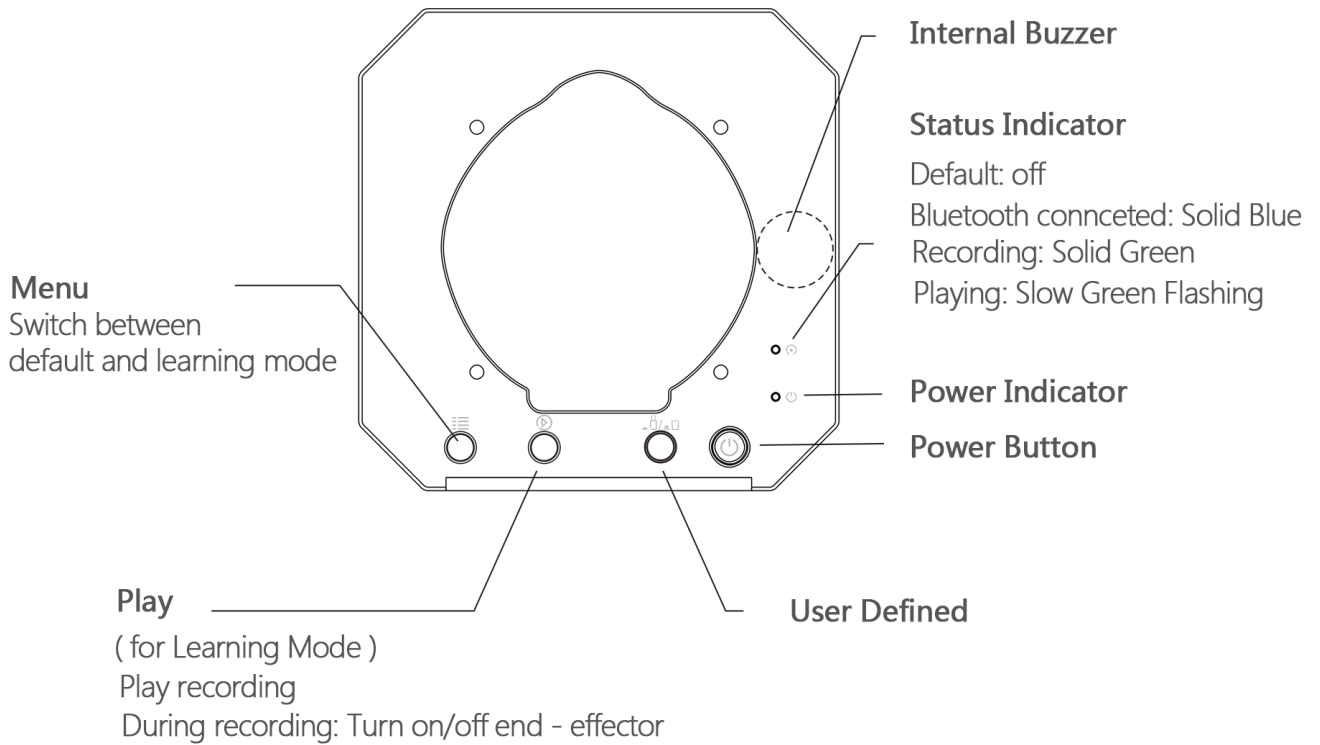

Caution: By default, the user defined button is for switching between Bluetooth and USB mode. Please ensure the button is UP while communicating with uArm via USB.

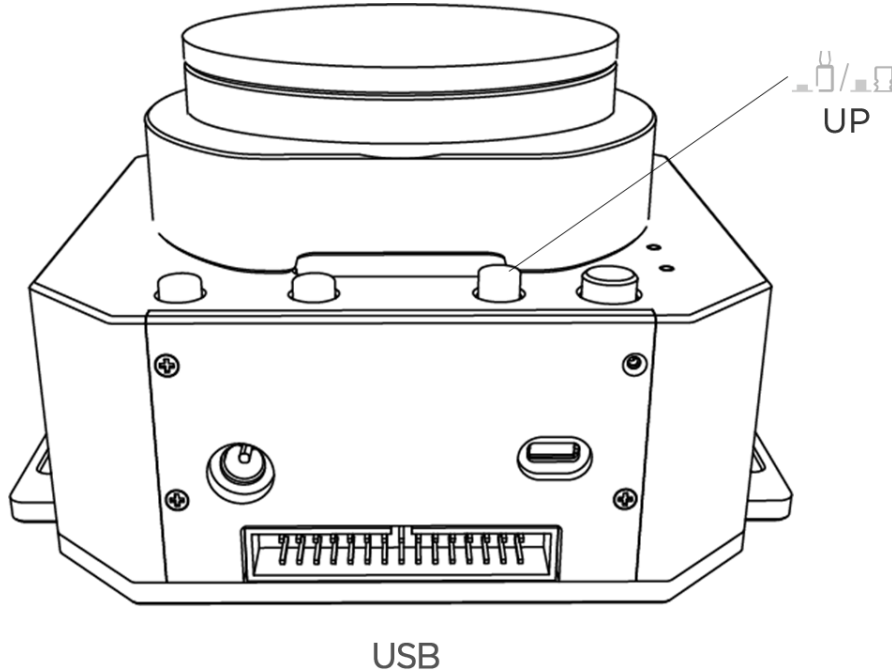

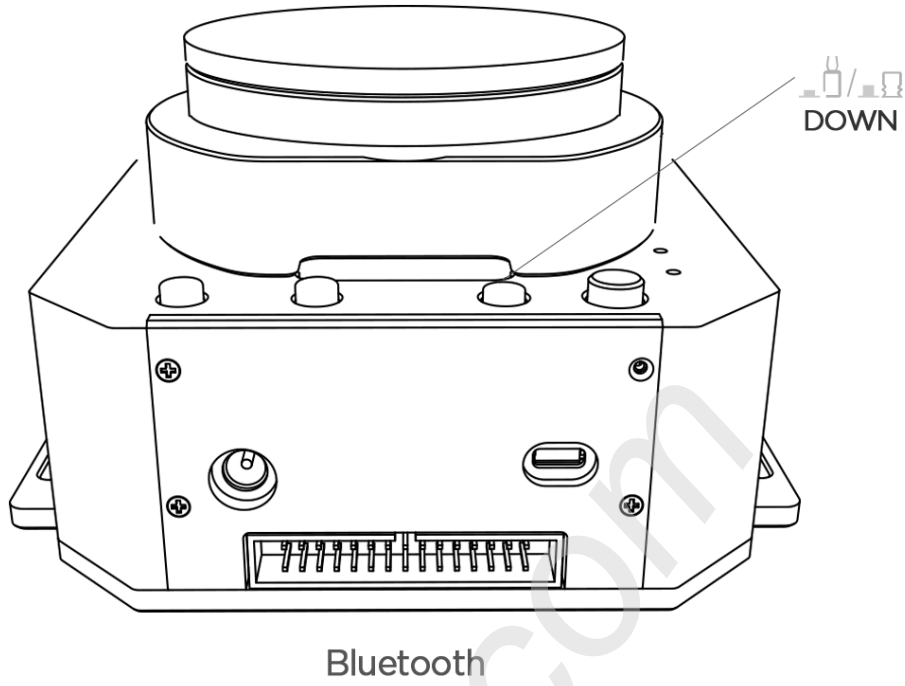

3. Extension Description

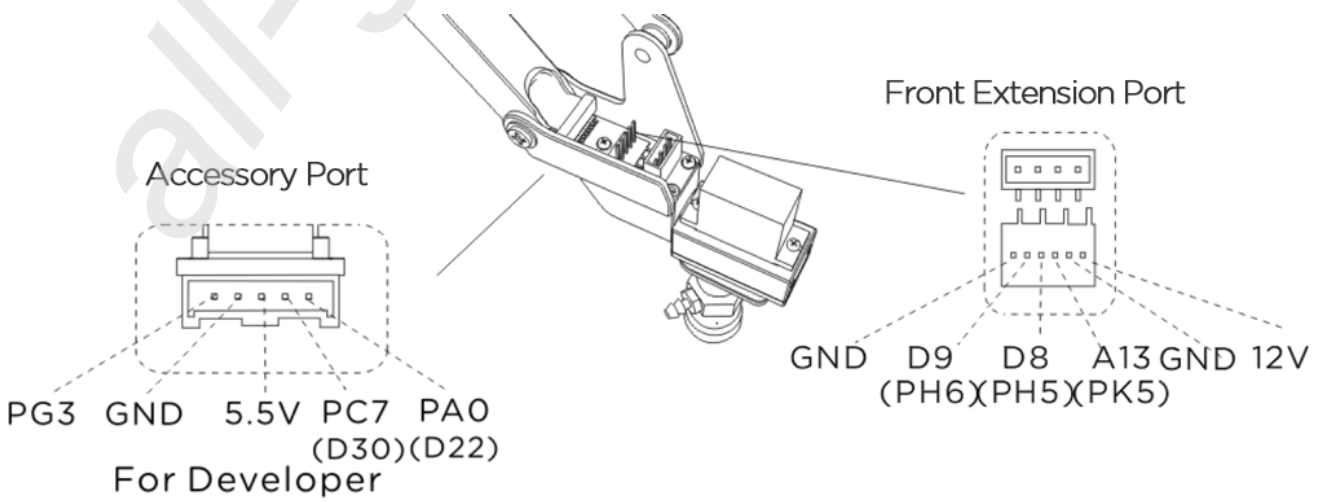
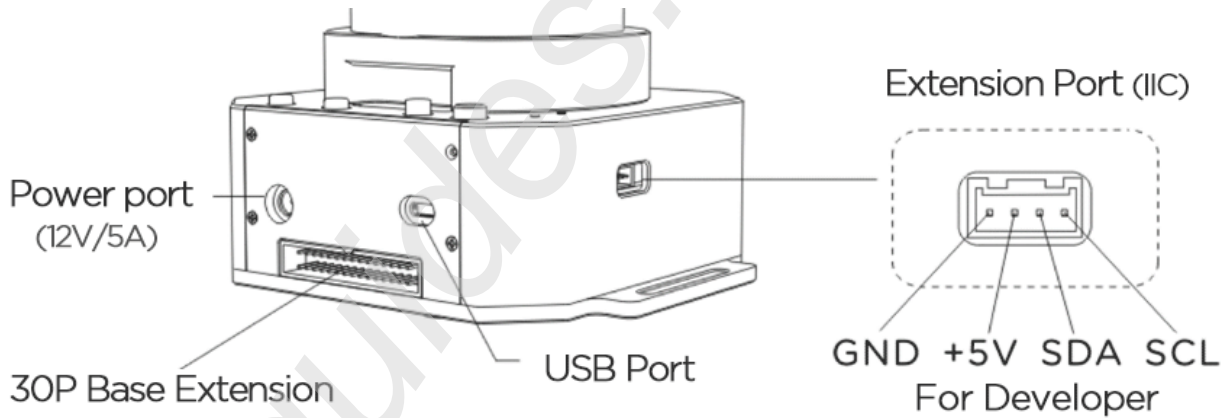

Hardware Installation

1. Suction Cup (Default)

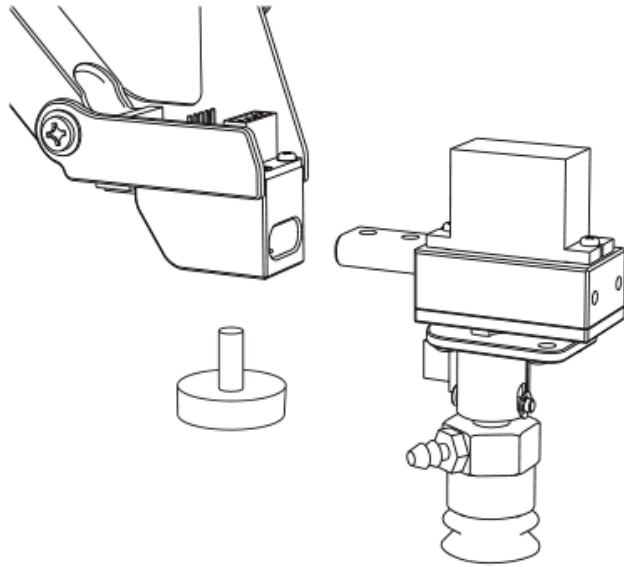

Preparation

Step 1: Install the suction to the end-effector and lock the nut tightly. **Note:** Similarly, if you want to uninstall suction cup, unlock the nut.

Step 2: Plug the wire of 4th axis motor, suction tube and limited switch

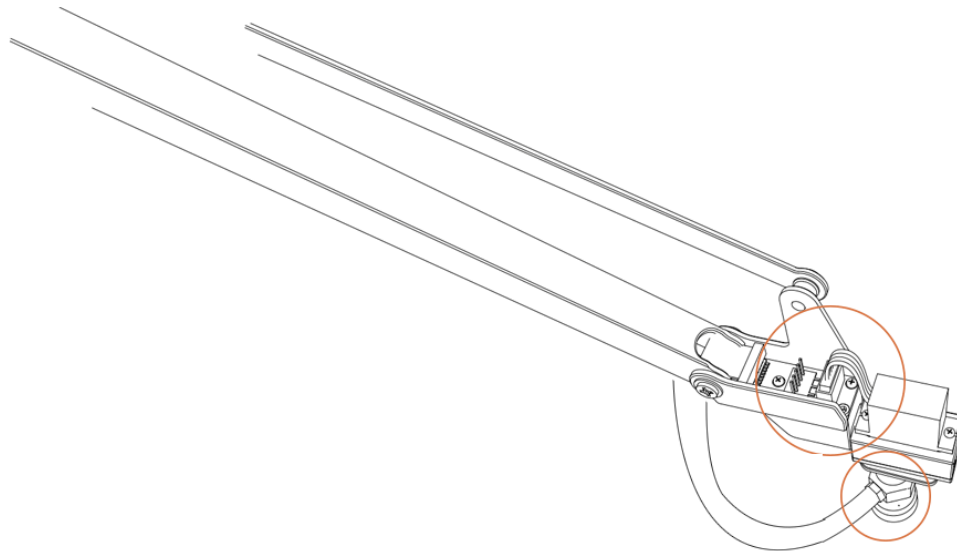

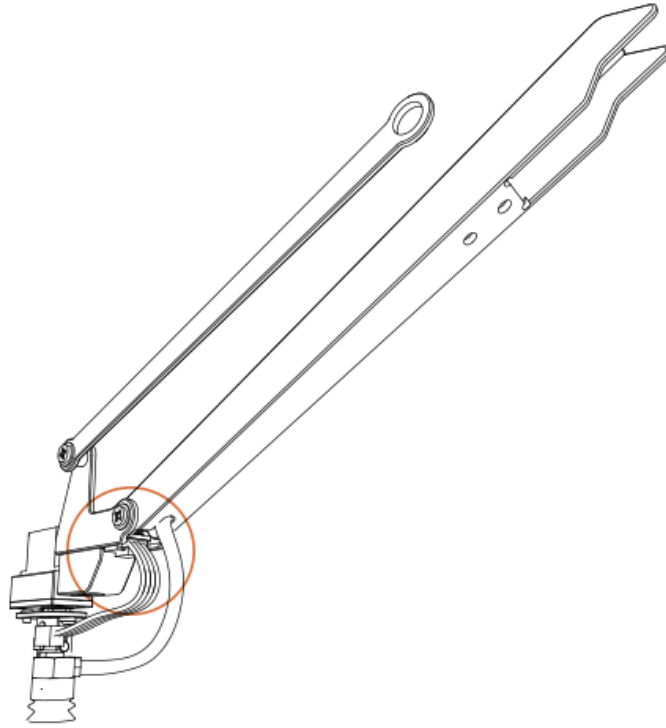

2. Laser

Preparation (Required Parts: Laser head, Thumb nut)

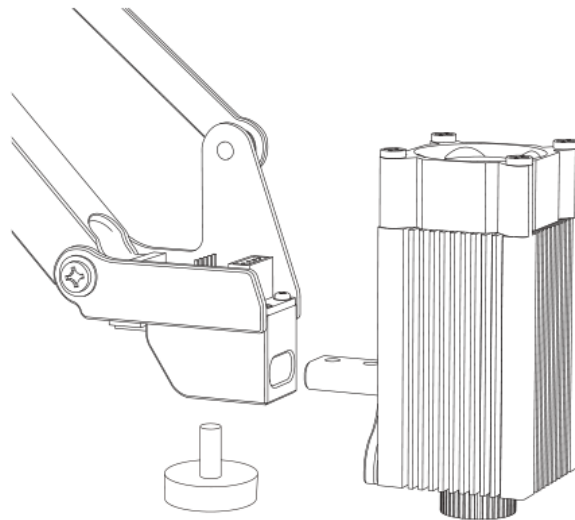

Step 1: Install the laser head and lock the nuts tightly

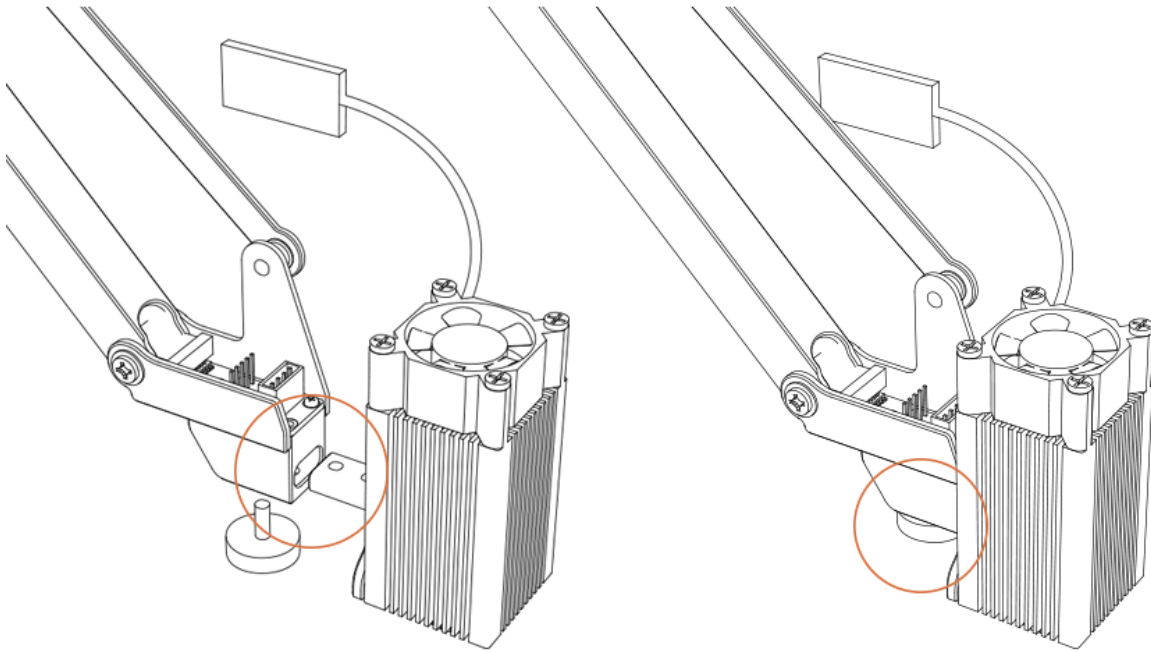

Step 2: Plug in the board of laser to the end-effector

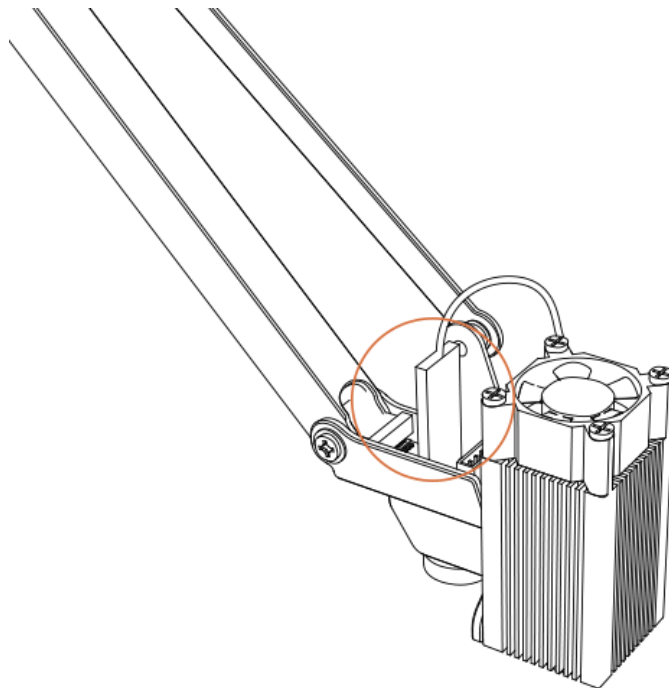

(Please pay attention to the direction)

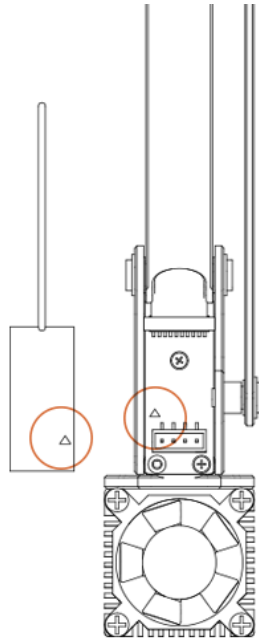

Caution: If the laser could not engrave the paper, please open the uArm studio and start the laser engraving, then focus adjust the lens of laser slowly. Please do not touch the light of laser during the engraving.

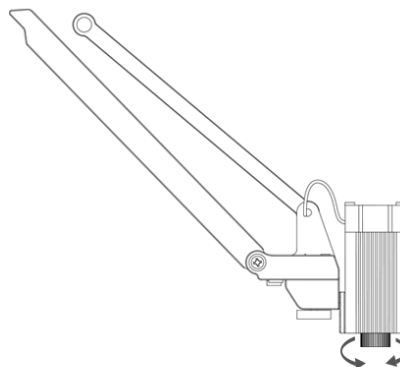
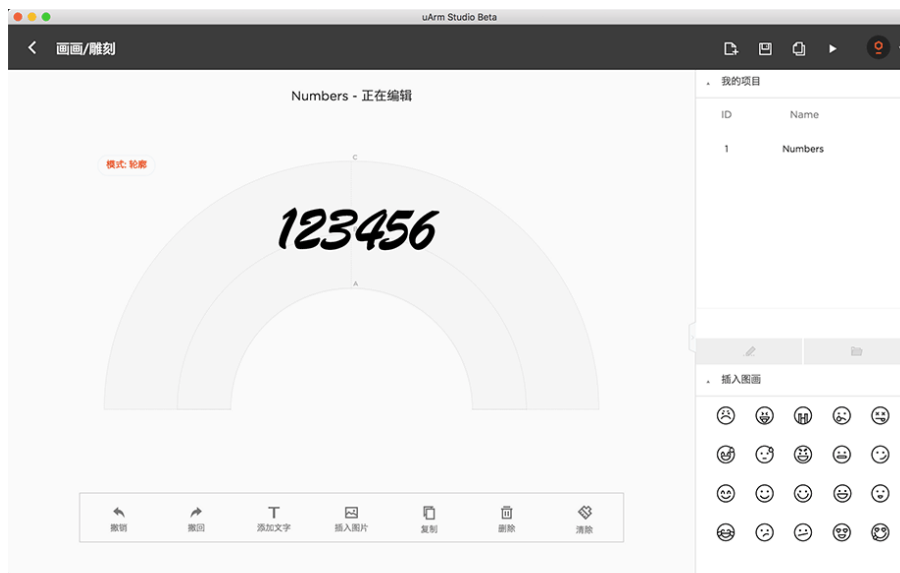

3. 3D Printing

Step 1: Install the 3D printing extruder and locked the nut tightly

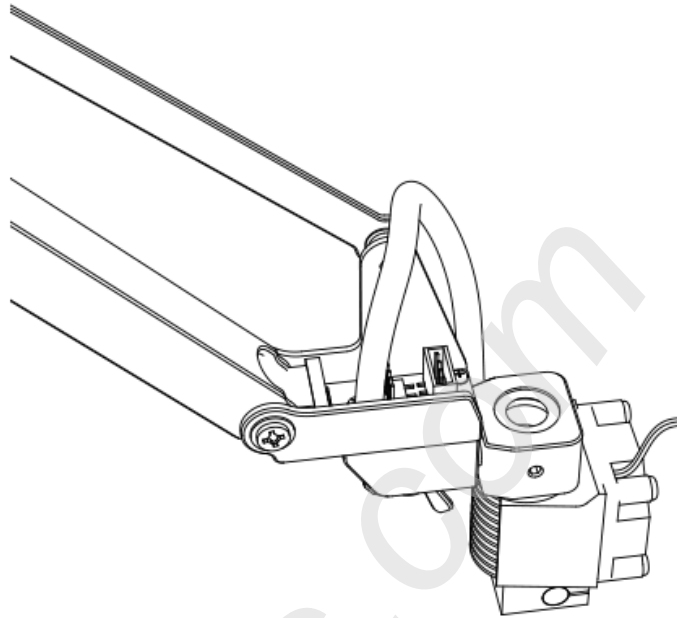

Step 2: Install the 3D printing feeding system

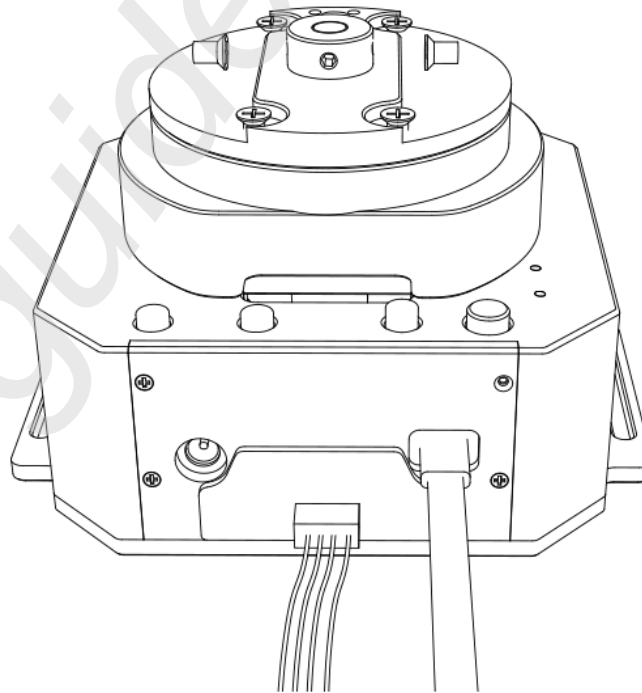

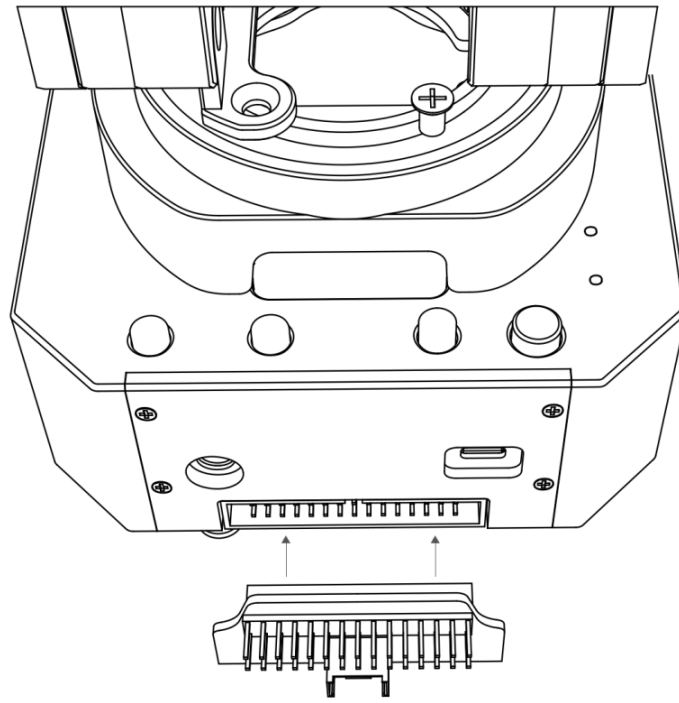

Plug in

Caution: Please ensure the connection is correct. Or the computer won't recognize the uArm Swift Pro (Connect the motor with the extension board with the 4-color cable).

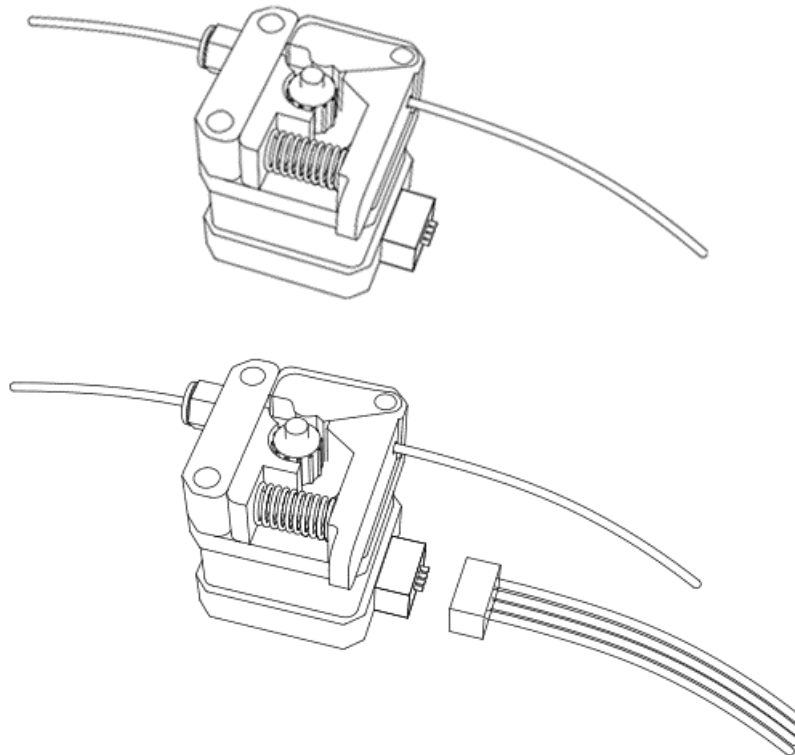

(Feed the PLA material we offered into the feeding system)

Step 3: Install the PTFE tube

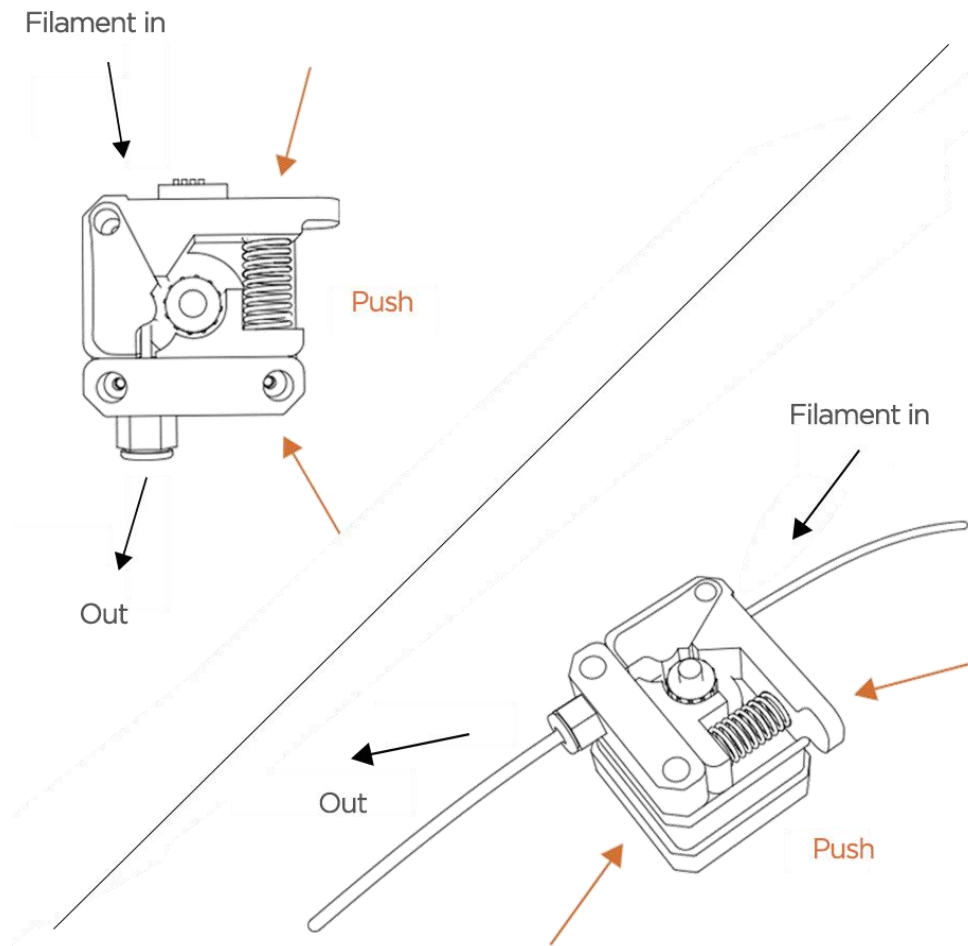

Feeding the filament and Installing the tube

Step 4: Keep feeding the material until it's 60mm out of the other side of PTFE tube.

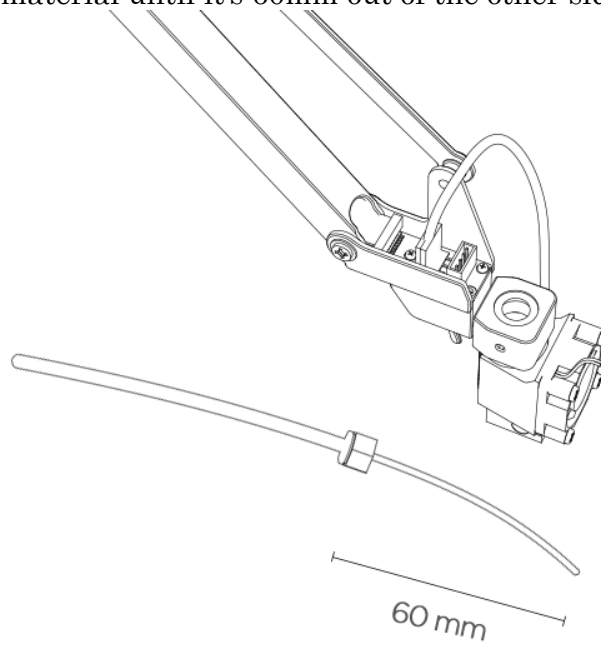

Caution: Sometimes the filament can't be extruded, that might be caused by the top of filament. If the tip is deformed during the cutting off, the filament won't go through the heat end successfully.

Step 5: Install the tube to the extruder

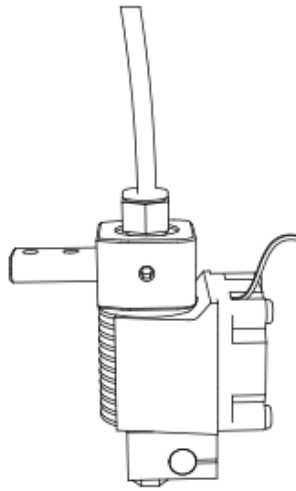

Step 6: Stick the masking tape on the table

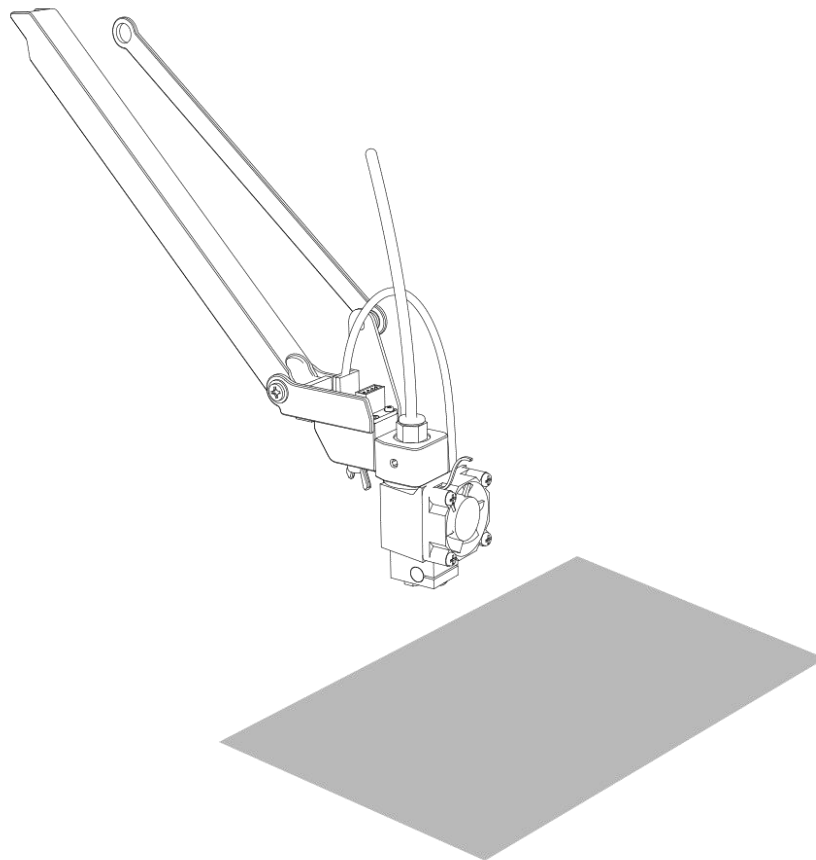

Caution: someone might get trouble with the not horizontal, please try to calibrate the arm following this [link](#) .

4. Swift Gripper

Preparation

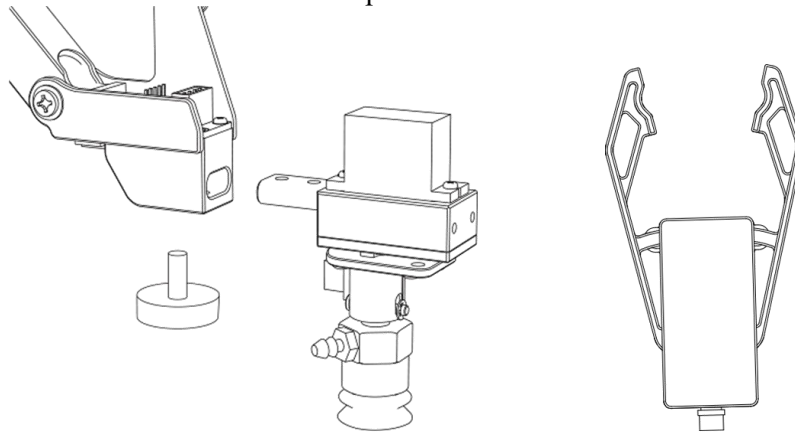

Step 1: Unscrew suction cup with the hex bar wrench.

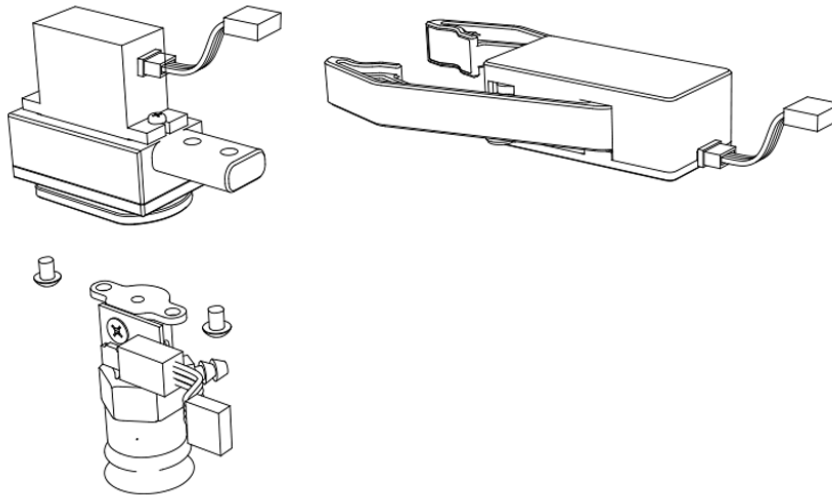

Step 2: Fix the gripper and lock the nut tightly

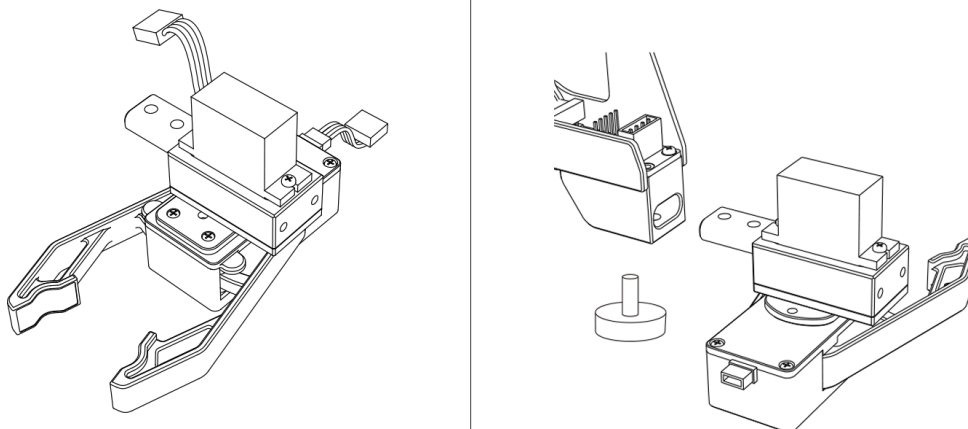

Step 3: Plug the 4th axis motor and gripper

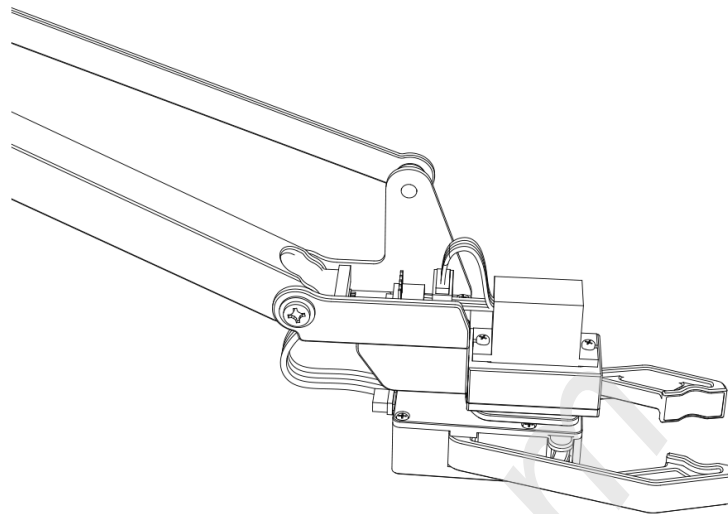

5. Swift Universal Holder

Preparation

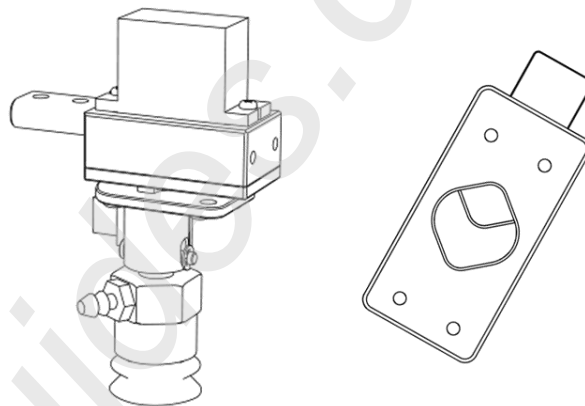

Step 1: Unscrew suction cup with the hex bar wrench.

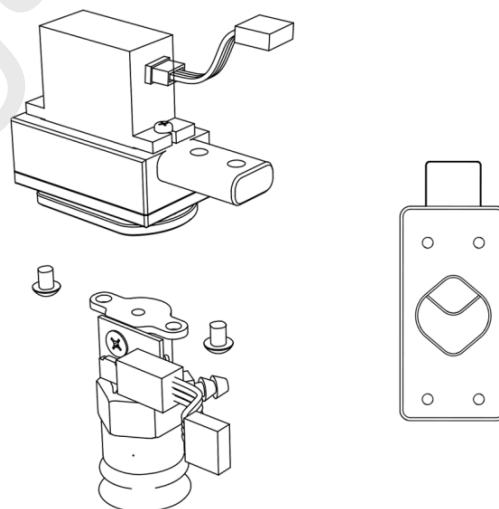

Step 2: Fix the gripper and lock the nut tightly

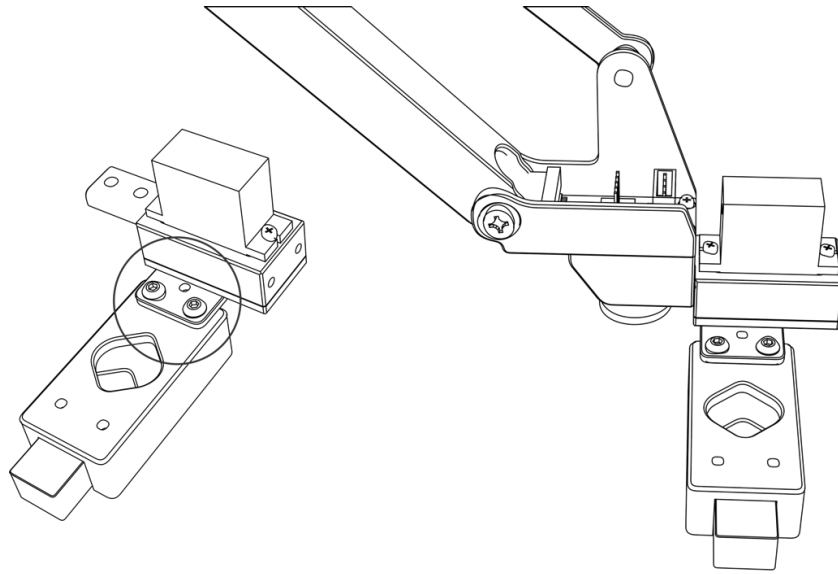

Step 3: Plug in the 4th axis motor

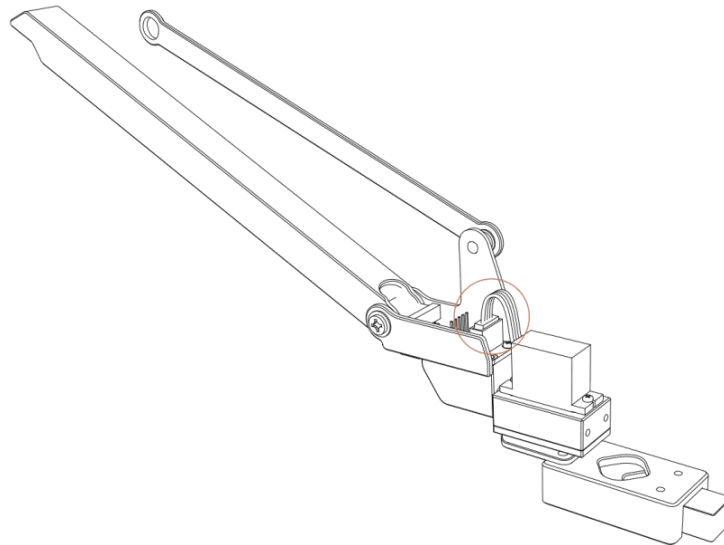

6. Seed Grove Modules

Seed Grove modules is a series of different sensors which helps us to extend the function of uArm to a completely new level. We are offering two parts to help you to connect the uArm with Grove much more easily.

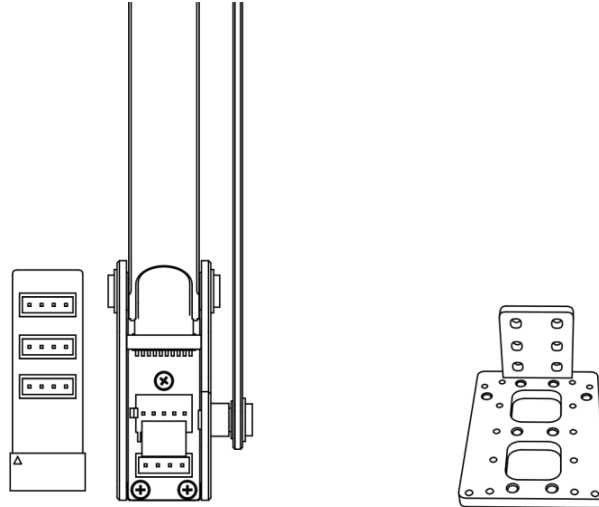

Grove Extension

Grove Mounting block

Caution:

Grove extension for the uArm end-effector is just designed for(Step 1,2)

- PIR Motion Sensor
- Mini Fan Module
- Electromagnet Module
- Ultrasonic Ranger
- Other Digital or Analog modules.

For the IIC module like: (Step 3)

- Temperature Sensor
- LCD RGB Backlight Module
- Color Sensor
- Gesture Sensor
- Other Digital or Analog modules.

Step 1: Plug in the Grove breakout and fix the grove module to the mounting block.

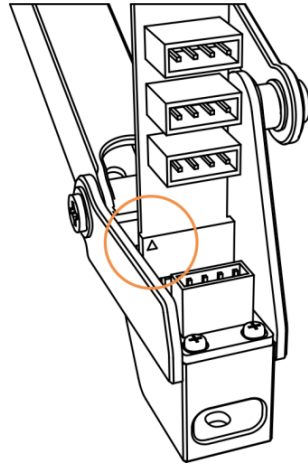

M2 hole for Grove/OpenMV

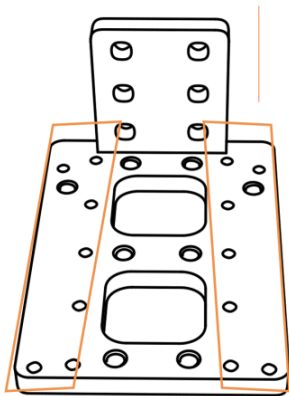

$\varphi 3$ hole for end-effector

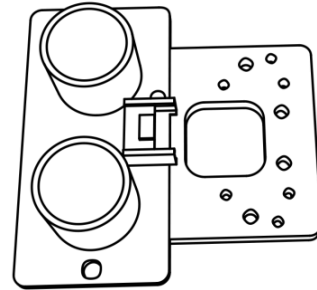
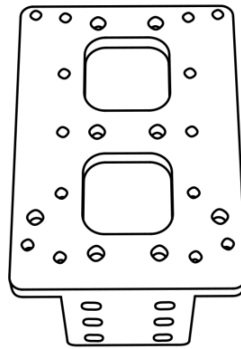

Step 2: Wiring

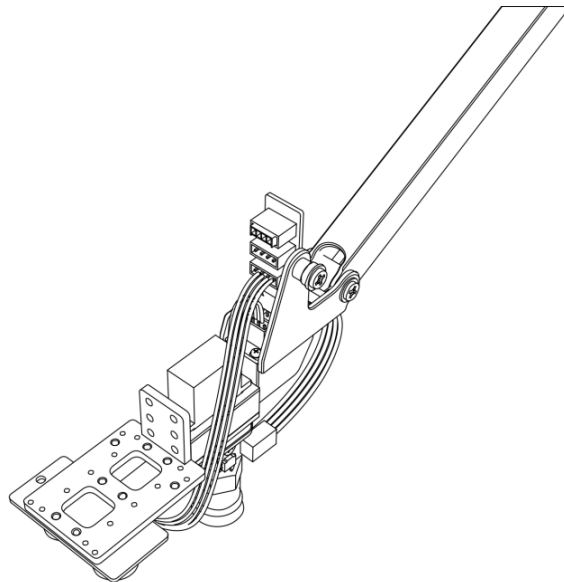
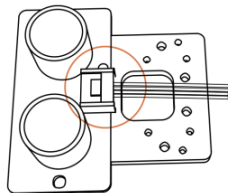

Step 3: For the IIC modules

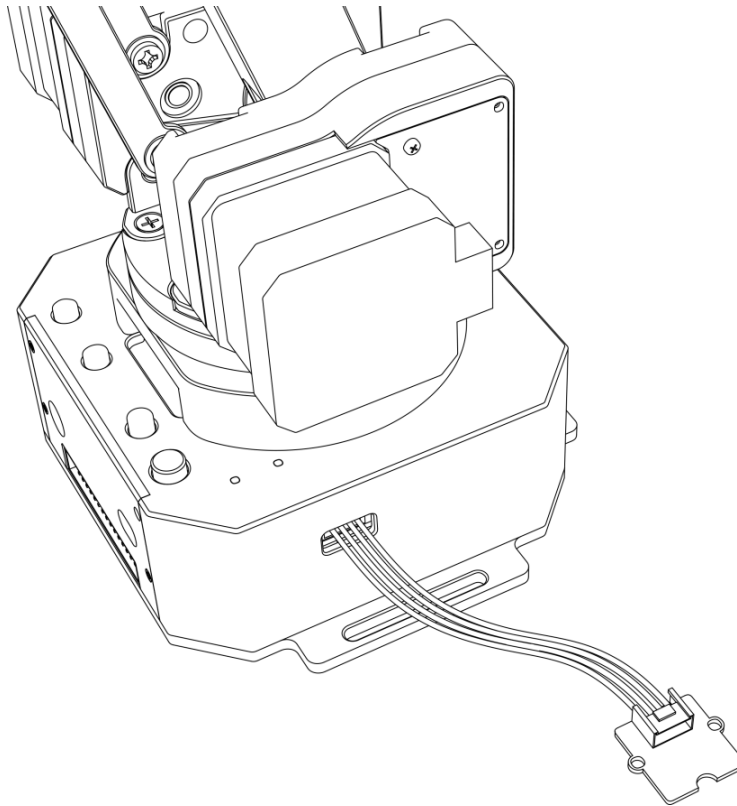

7. OpenMV Module (the firmware should be 3.1.9 or later)

Preparation

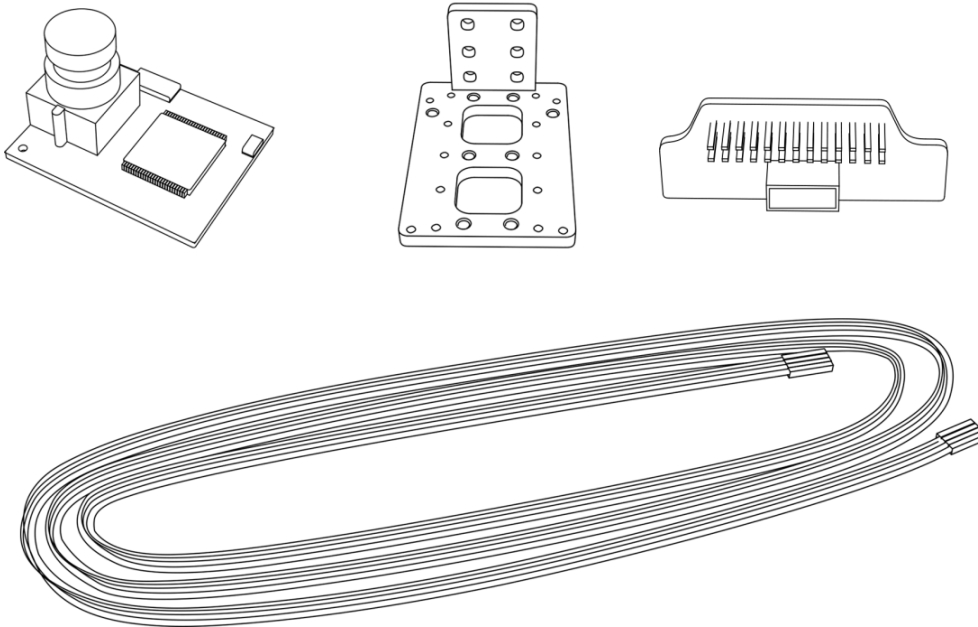

Step 1: Download the latest OpenMV IDE

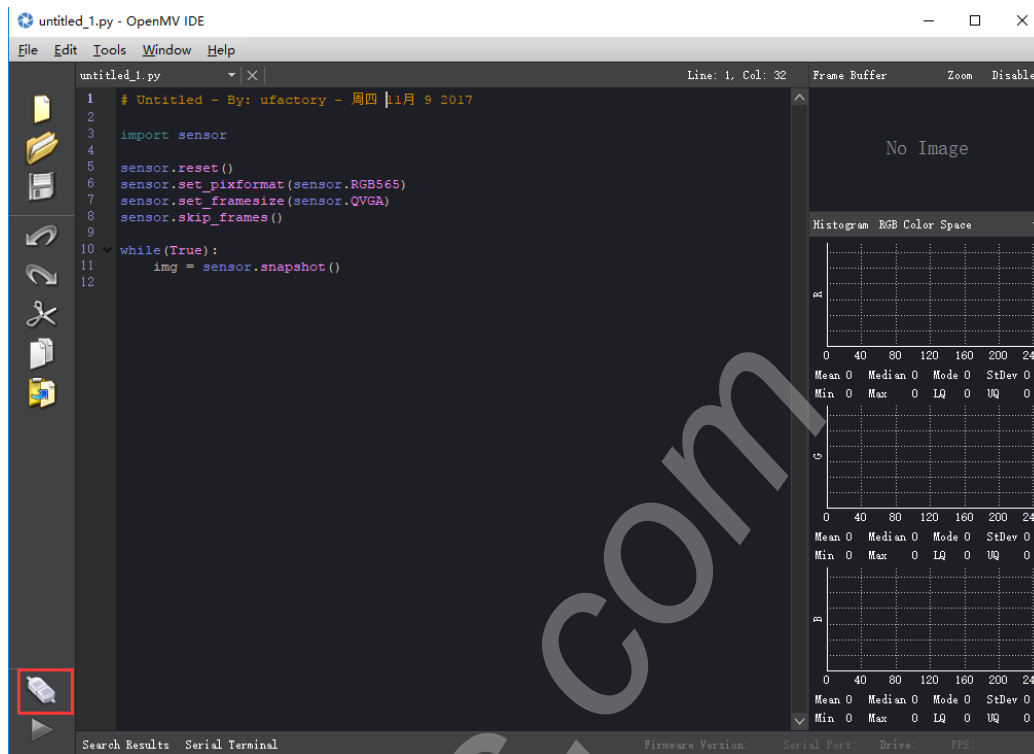

(Download the latest OpenMV IDE from: <https://openmv.io/pages/download> and plug in the OpenMV camera to the computer , click the “Connect” button on the left bottom of picture)

Step 2: Upgrade the latest firmware to OpenMV by OpenMV IDE

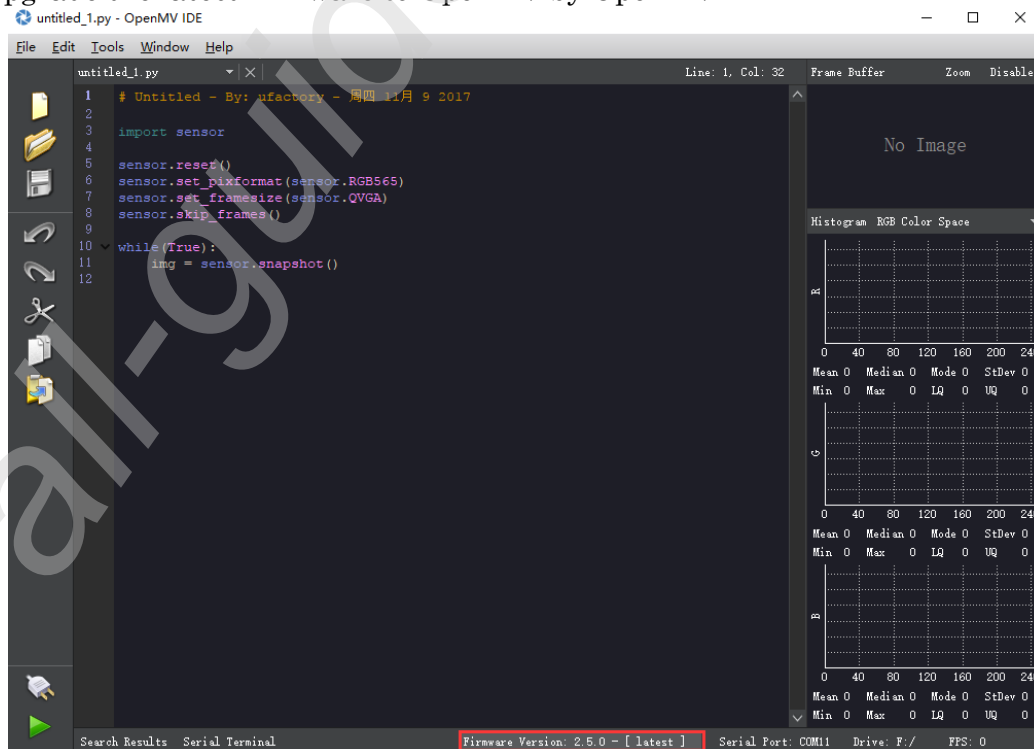

Step 3: Run the “helloworld.py” (By clicking the “play” button as image below) and focus the lens in the right window

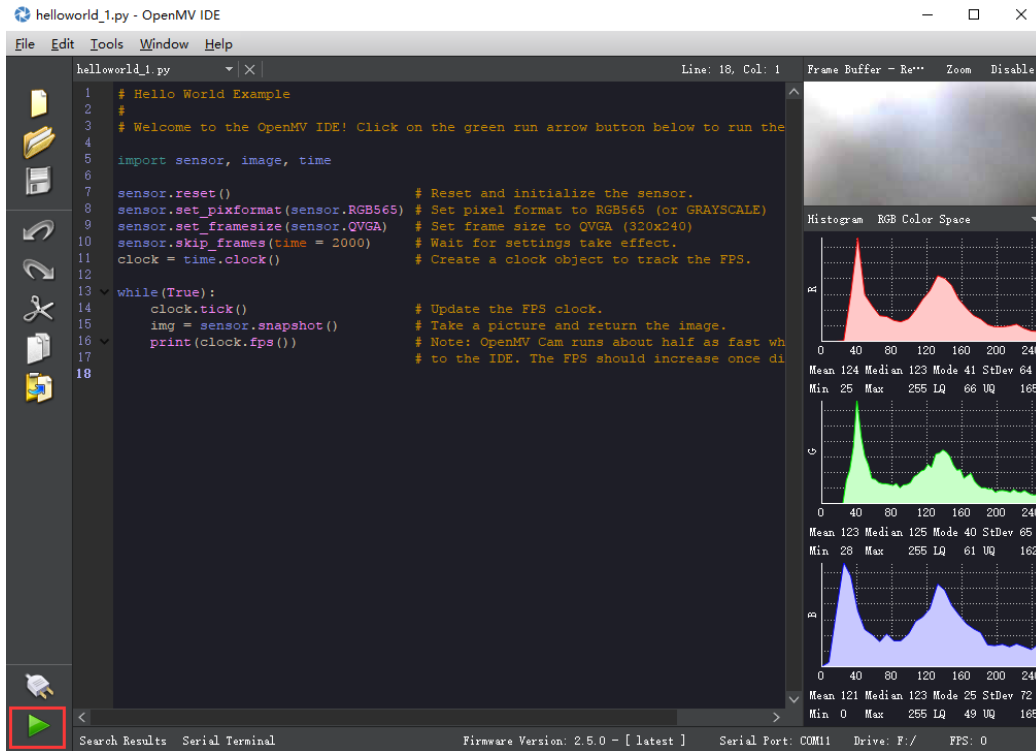

Note: After IDE get the video, then rotate the lens to finish focusing (to see the objects 20cm away) then tight the screw.

Step 4: Get the tracking.py code and save it to the OpenMV

- (1) Download “tracking.py” from:
<https://github.com/uArm-Developer/OpenMV-Examples>
- (2) Click “File” —”Open File” to export tracking.py

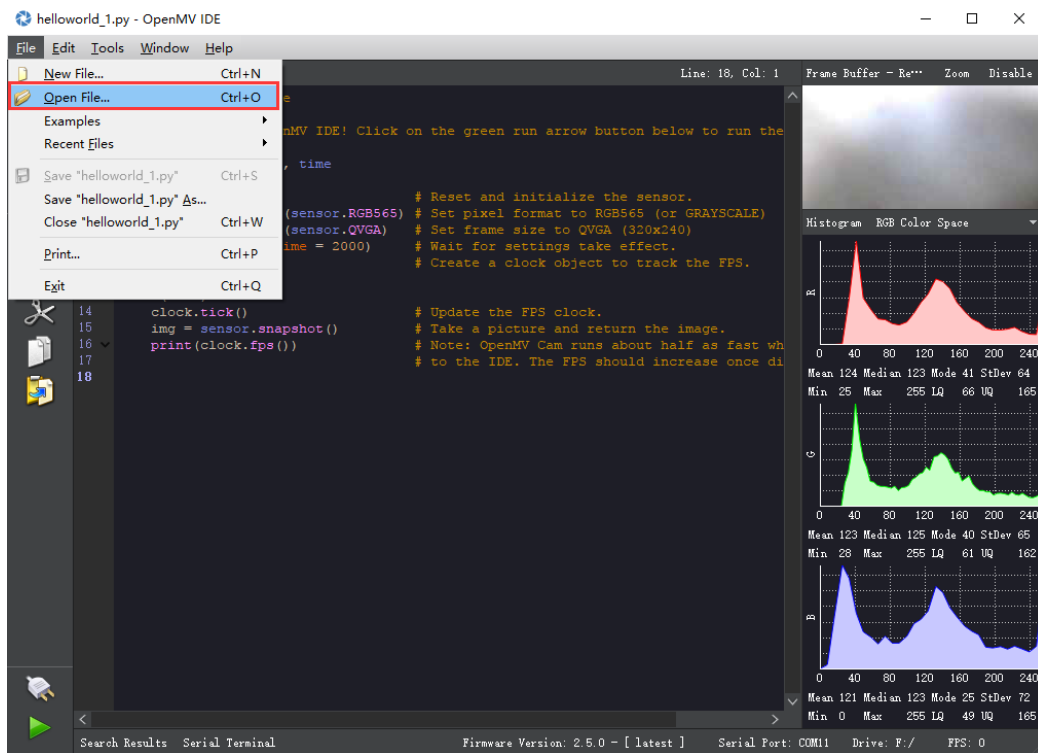

- (3) Click “tool”——“Save open script to OpenMV Cam”, after the code has been stored, restart the Open MV module(remove the USB cable form Open MV and then plug the USB cable to Open MV). If the code stored successfully, the LED on Open MV will be solid blue.

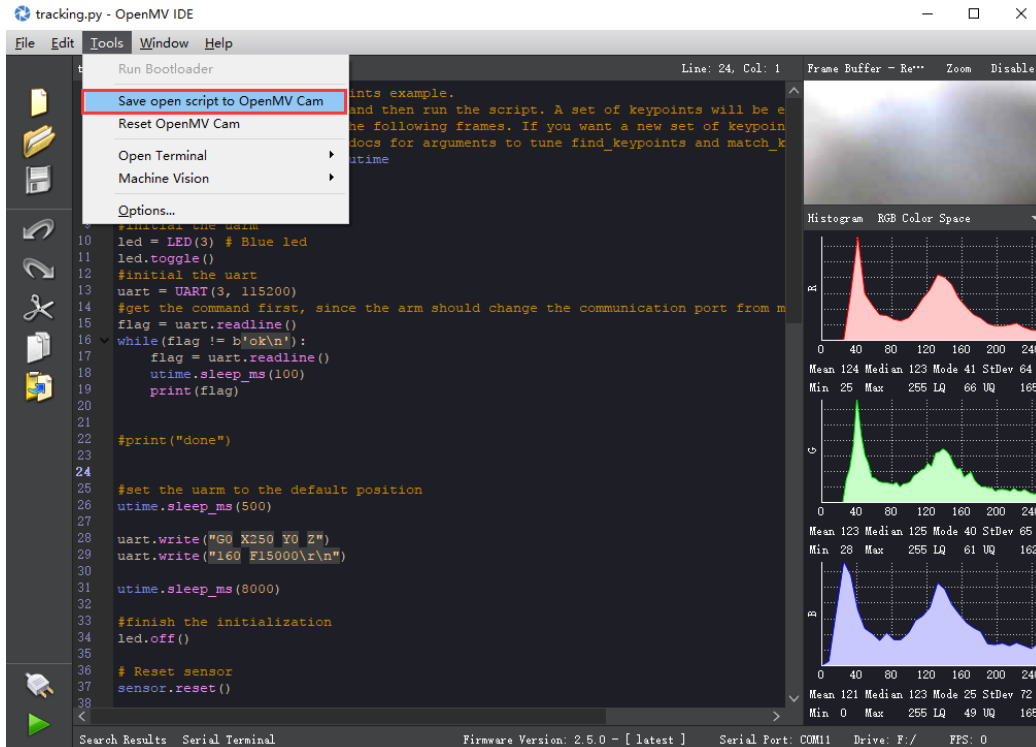

Step 5: Remove the USB cable from OpenMV module and wiring the OpenMV to uArm

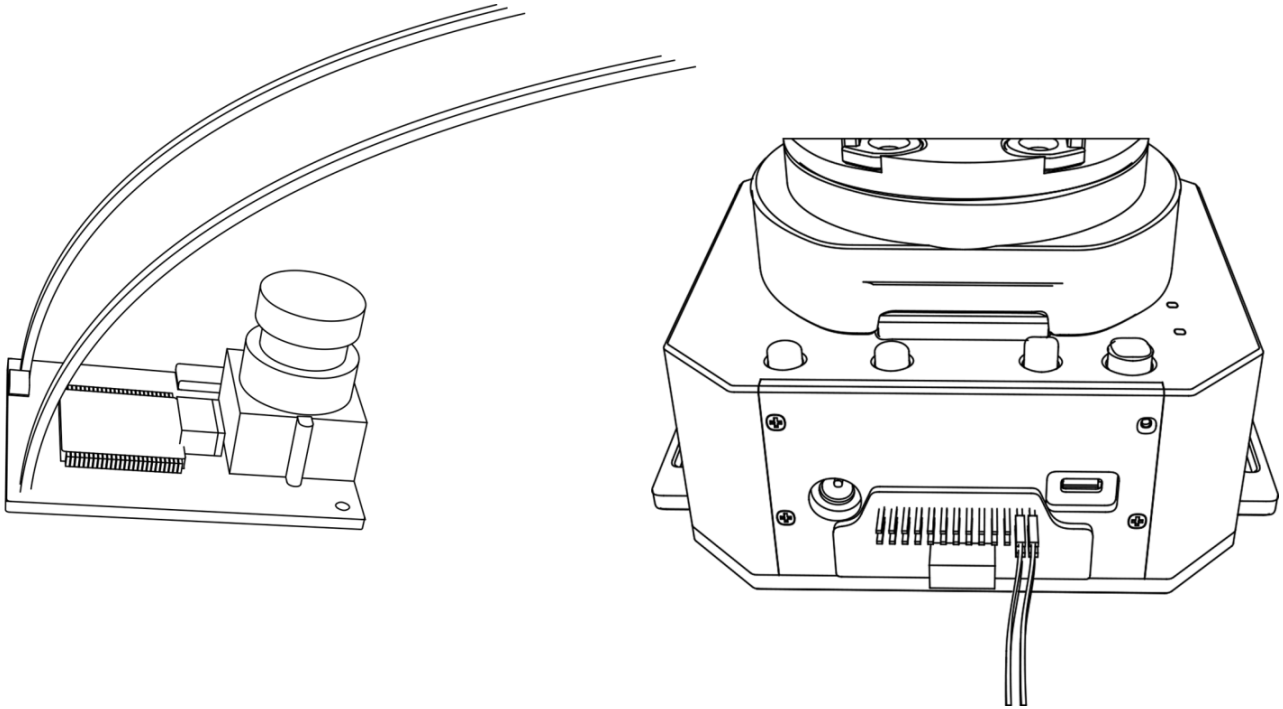

Caution: Please ensure the connection is correct. otherwise the computer will not recognize the uArm.

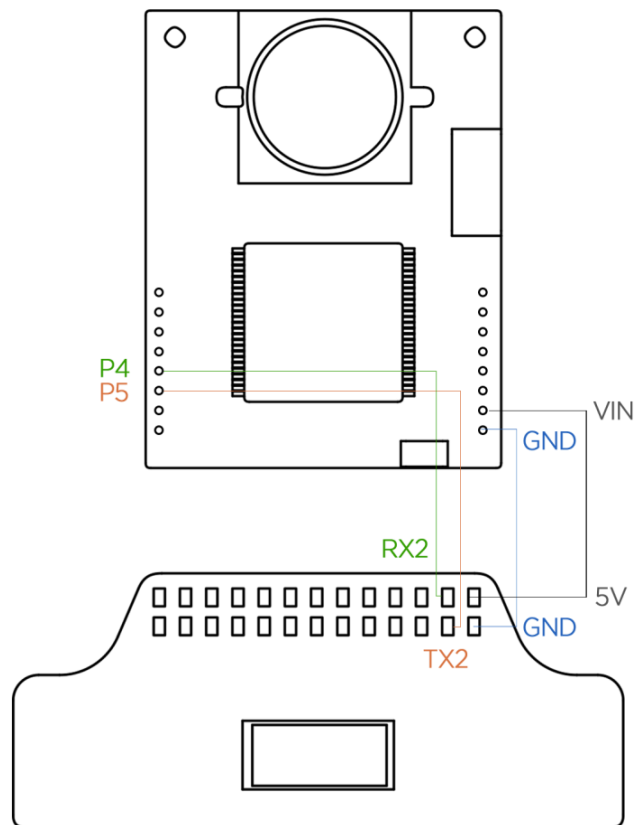

Step 6: Install the camera module to the end-effector

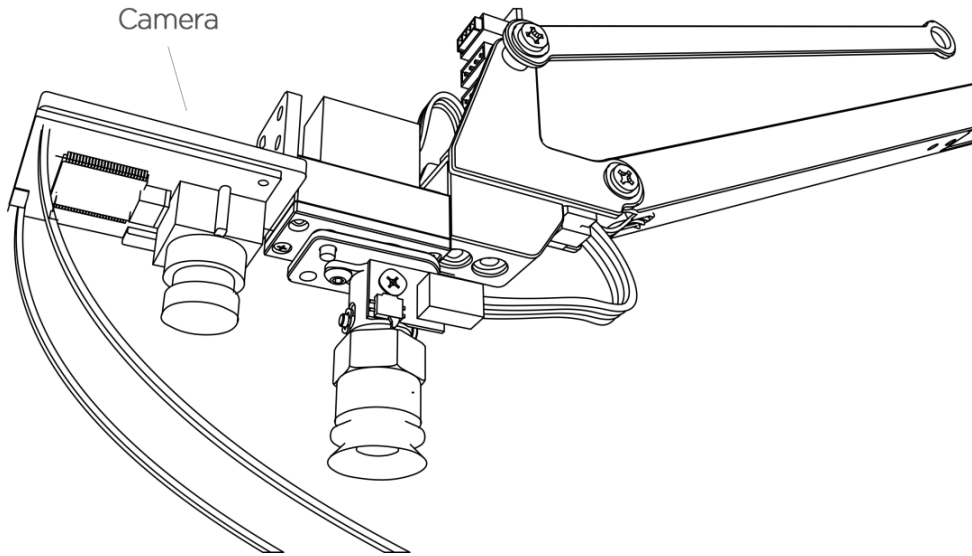

Note: Please pay attention to the assembling direction of OpenMV, or the arm will move to the opposite direction. And make sure the OpenMV is disconnected with you PC or the IDE will control the OpenMV.

Step 7: Keep the table clean and non-reflective and get something with a lot of details like a PCB with resistors.

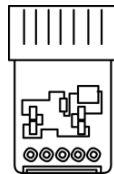

Step 8 : Put the object in front of uArm Swift Pro about 25cm away , OpenMV will recognize the object.

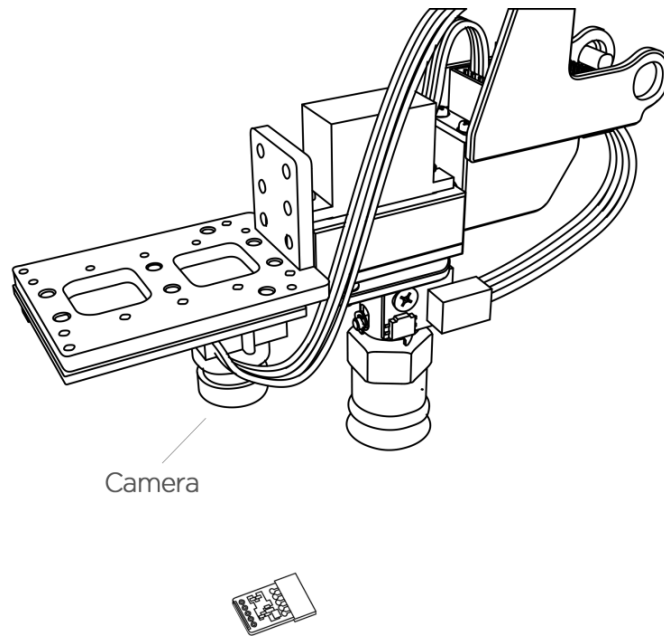

Step 9: Connect the USB port and power port of uArm, press the power button of uArm. Open the Arduino IDE (Download Arduino IDE <https://www.arduino.cc/en/Main/Software>), Choosing the right port: COM (Arduino/Genuino Mega or Mega 2560)

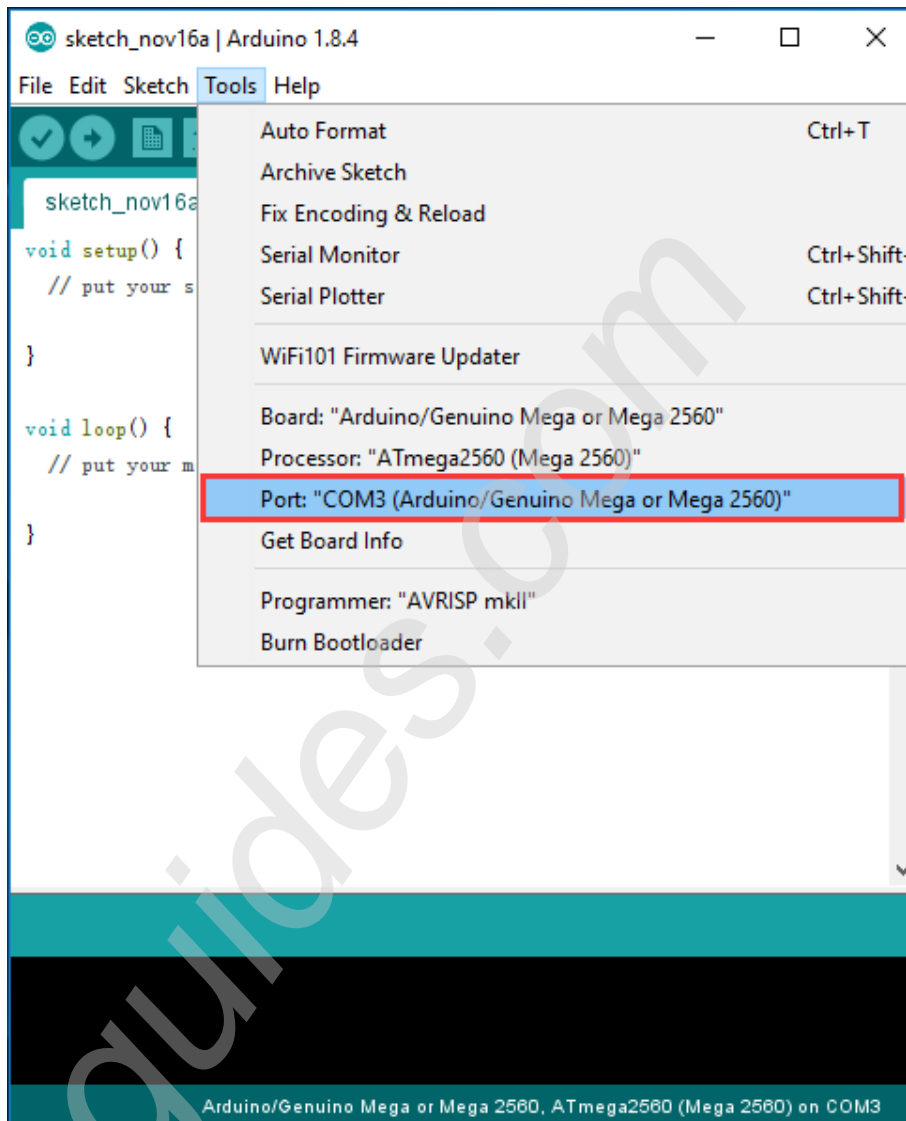

Step 10: Click the serial monitor button to open a serial monitor.

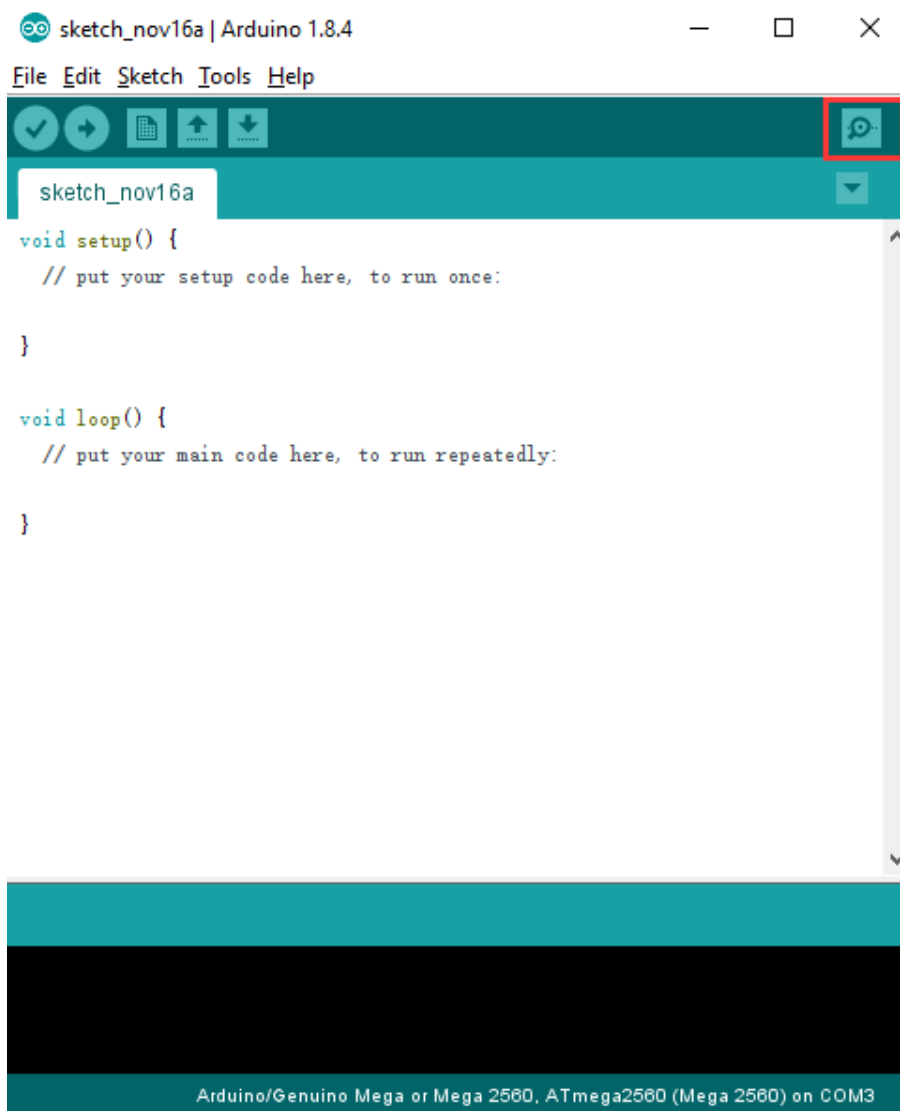

Step 11: Adjust the settings (newline & 115200 baud) and then send the M2500 command to switch the main UART port of uArm from USB to the port of OpenMV.

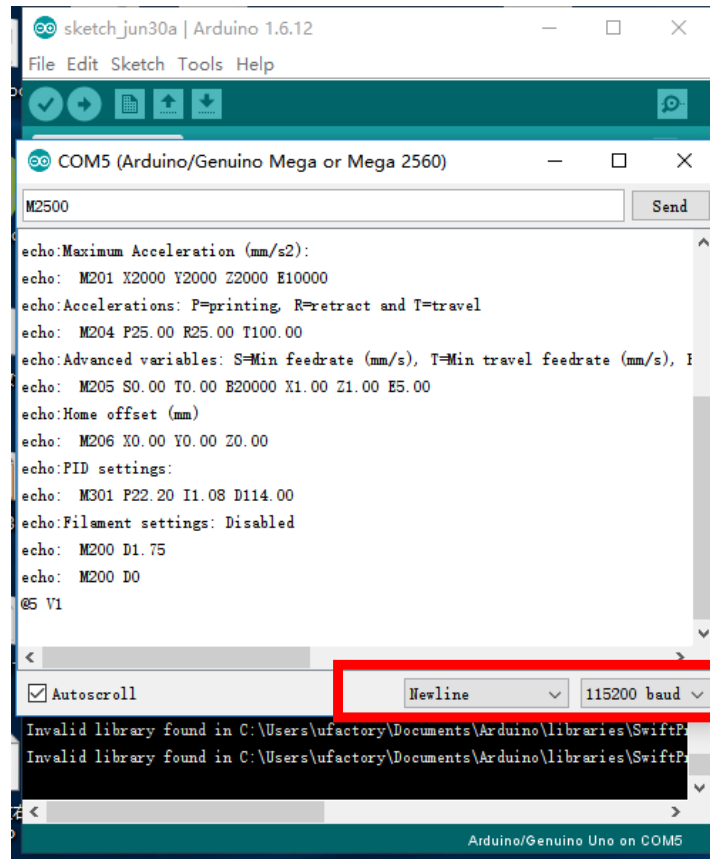



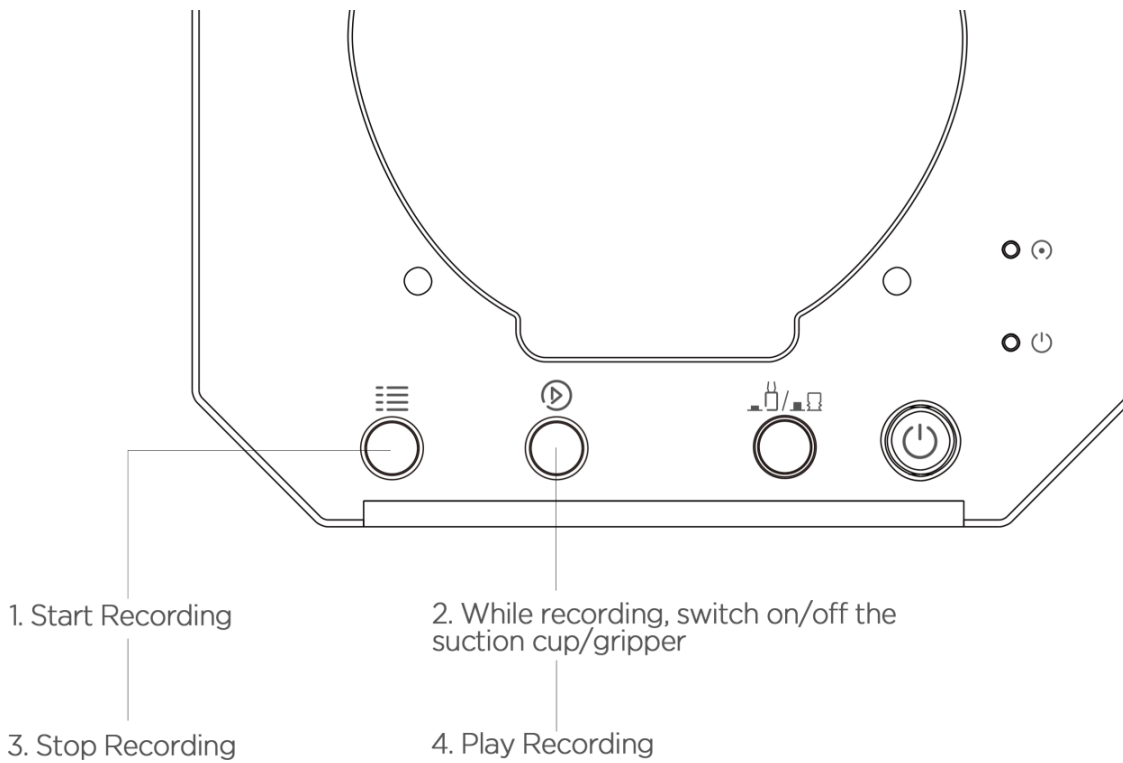

Step 12: Move the object slowly, and the arm will follow it.

Offline Learning Mode



Use buttons on the base to “teach” uArm by hand



TEACH:

1. Start learning mode. Press the  once, and the status indicator turns green.
2. Teach the robot manually. Press the  once to turn on the end-effector, again to turn off. (If  is down end-effector is gripper, or it is pump. Please remember to keep the button up after learning or it will turn on the Bluetooth. Page 5)
3. Finish the learning process. Press  once, and the status indicator turns off.

PLAY:

1. One-time playback: Press  once, or Loop playback: press  & hold for 2 seconds.
2. The status indicator starts flashing green slowly.
3. Press  once to stop playing.

Software: uArm Studio (Win/Mac)

1. Download uArm Studio **from:**

<http://www.ufactory.cc/#/en/support/>

* Windows (Win7/8 or before) users will be reminded to install driver.
Simply follow the instructions to install.

2. Device Connection

- 1) Plug in the power cable.
- 2) Press down the power button.
- 3) Connect uArm to your computer via USB.

Status of device connection is displayed on home page.
More info is displayed in “Setting”.

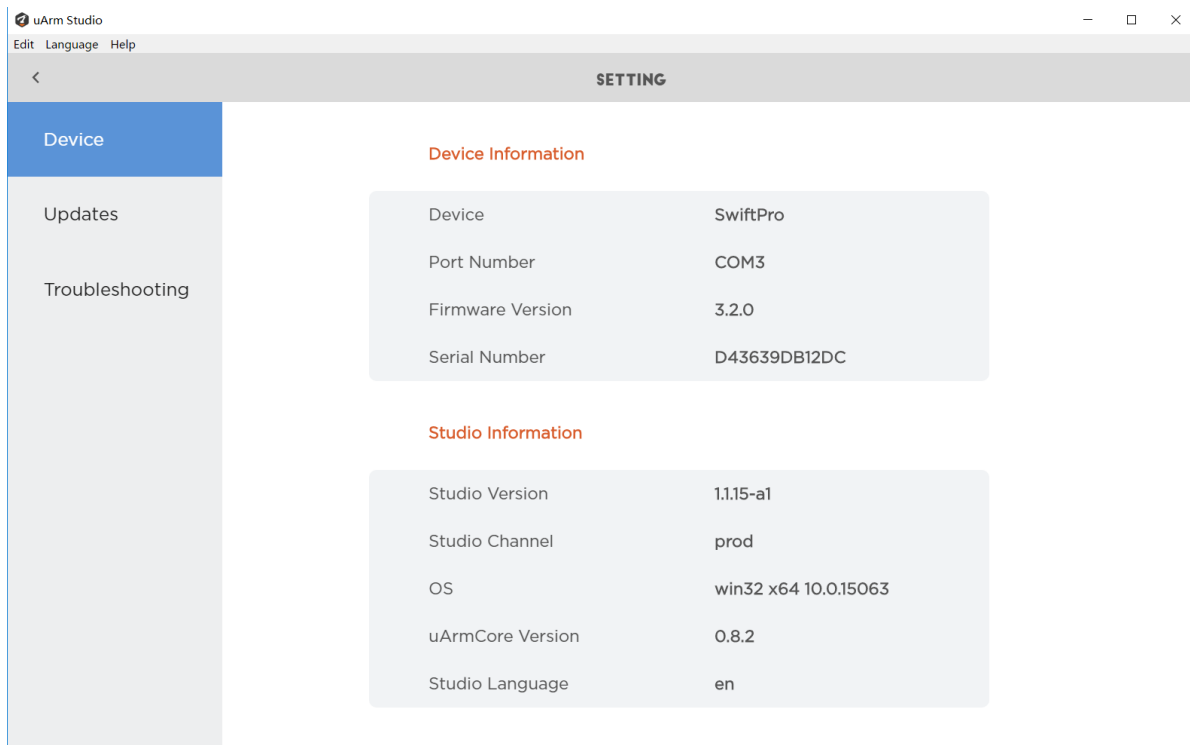
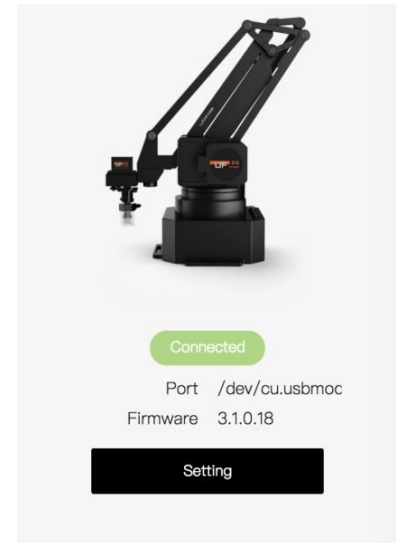

3. Drawing/Laser Engraving

Design a pattern:

Insert text/shape



Insert

image
("Outline" or "Black & White")

an



- 1) Click the play button to continue.
- 2) Adjust Zero Point

- 3) **⚠ IMPORTANT:** Please adjust zero point before drawing/engraving. Ensure the pen/laser is TOUCHING the platform. For laser engraving, you can also adjust the speed of engraving.

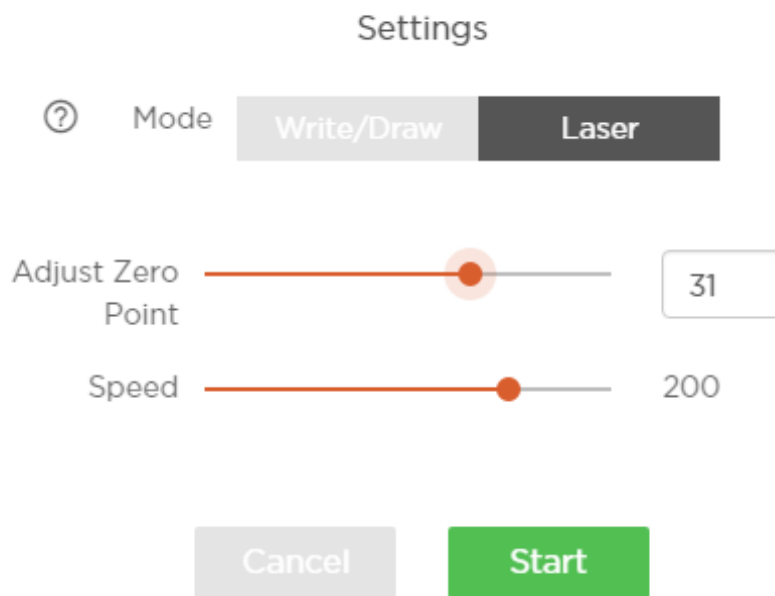
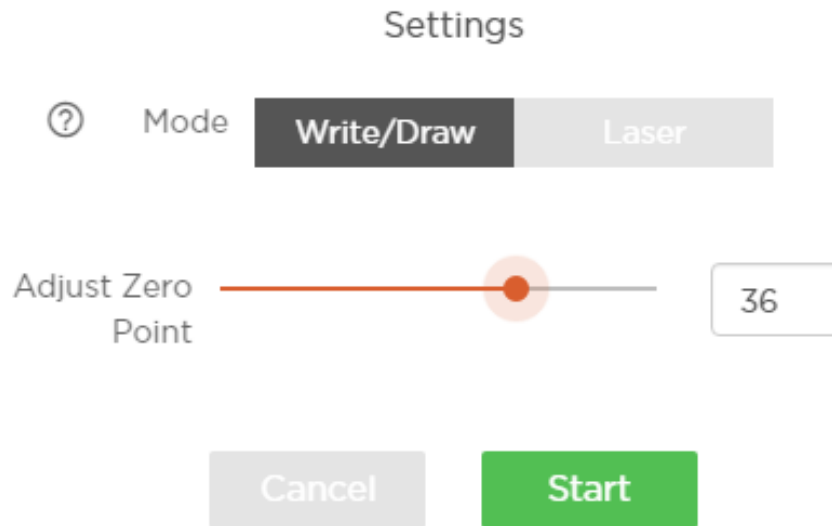

- 4) Start drawing/engraving!

4.3D Printing

Preparation

- 1) [Download CuraForuArm](#)
- 2) Double-click .dmg/.exe file to install.
- 3) Enter the 3D Printing section in Studio, and CuraForuArm window will pop up automatically. If not, click the “Open Cura” button.

CuraForuArm Interface

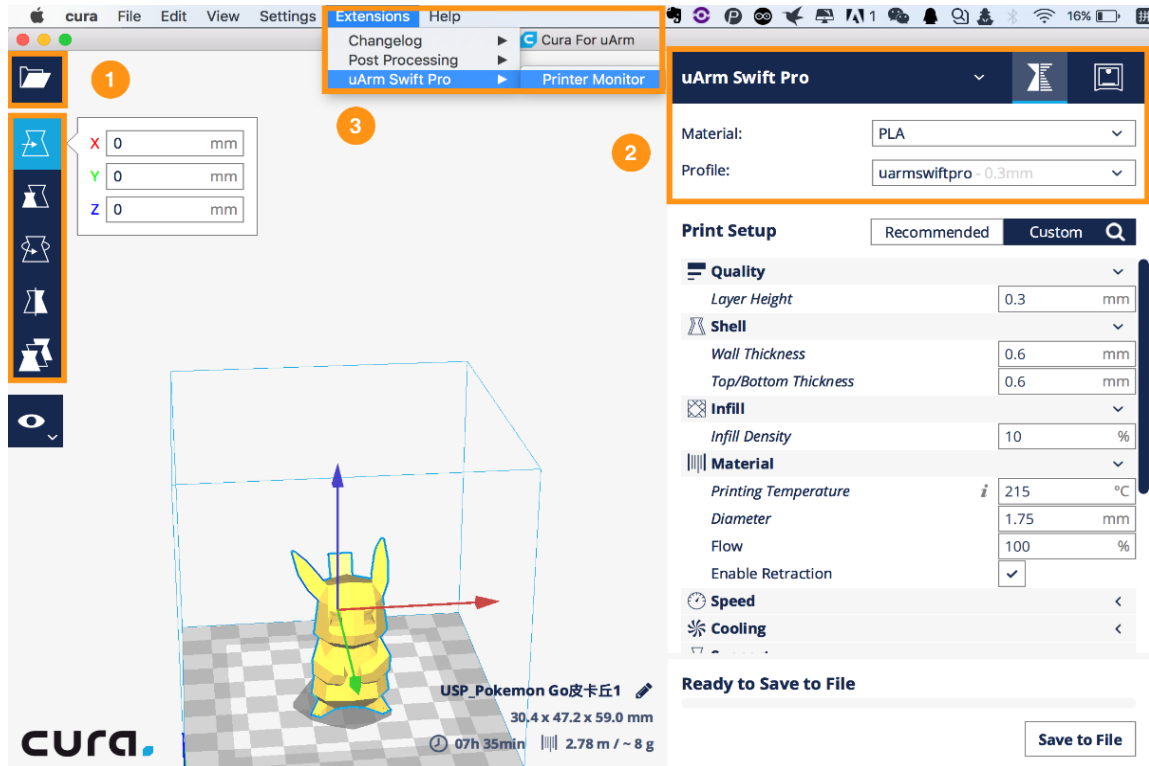

- 4) Import an .stl file, edit the size/position of the model.
- 5) Select “uArm Swift Pro” as the printer, and choose the related profile. It is recommended to keep the default settings unchanged.

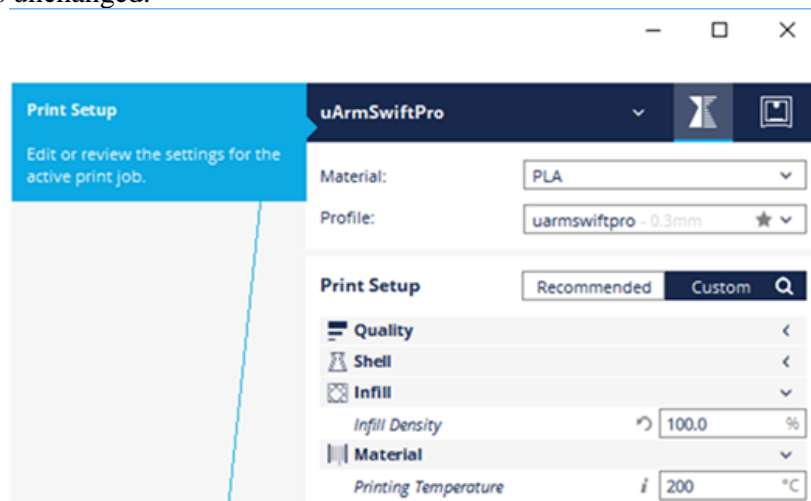

When setting the parameters of printer please choose the print setup option (orange rectangle), if you choose the printer monitor option (the right button) you can hardly find the printer.

- 6) Open Printer Monitor. **! IMPORTANT:** Please adjust zero point before printing. Ensure the hot end is JUST TOUCHING the platform. Then click “Save Zero”. (The zero point of each arm is not the same, please adjust the zero point following the step 3) before printing.)

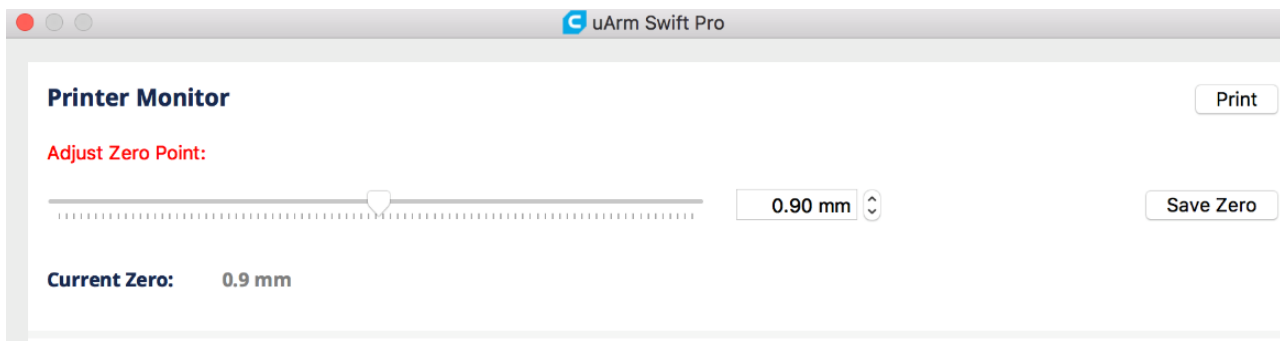
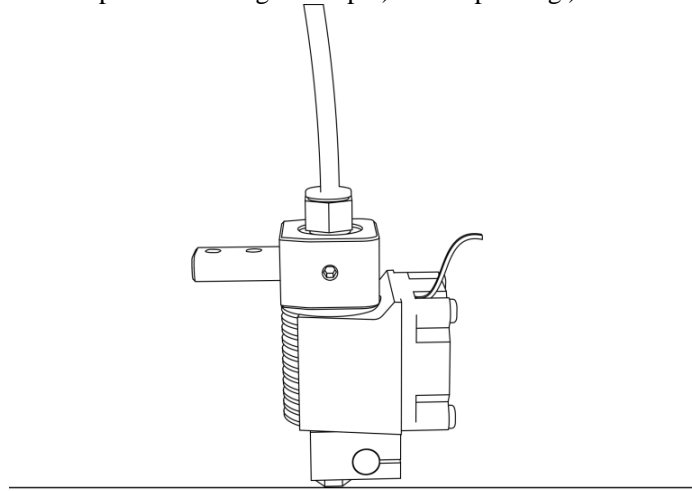

- 7) Start printing!

The 3D extruder will automatically heat up to 200 °C to print. uArm will remain still during the pre-heating section. Please don't touch the metal part of the extruder for safety reason.

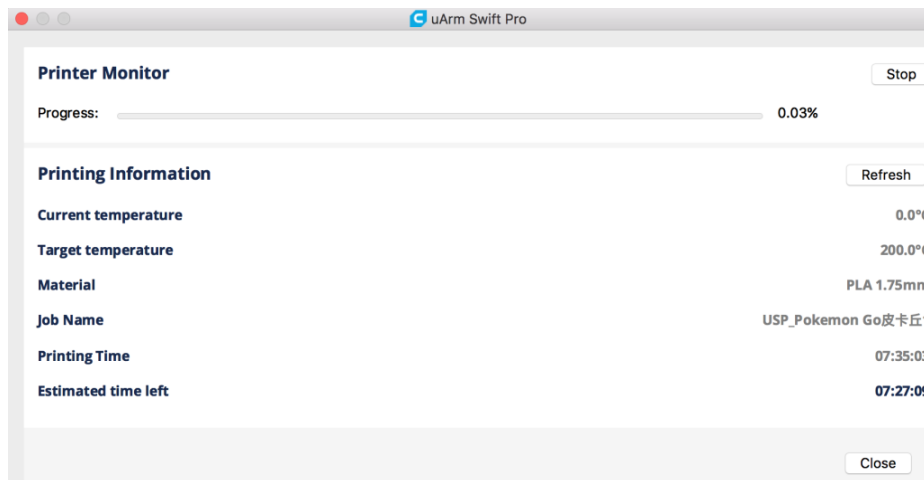

5.Teach & Play: Learning Mode

What is Teach & Play?

Teach uArm by hand, and then replay the recording anytime.

How?

1) Make a recording

- Click the “New Recording” button to start “teaching”, OR,
- Use the buttons on the base (usage of the buttons is the same as that under “Offline Learning Mode”).

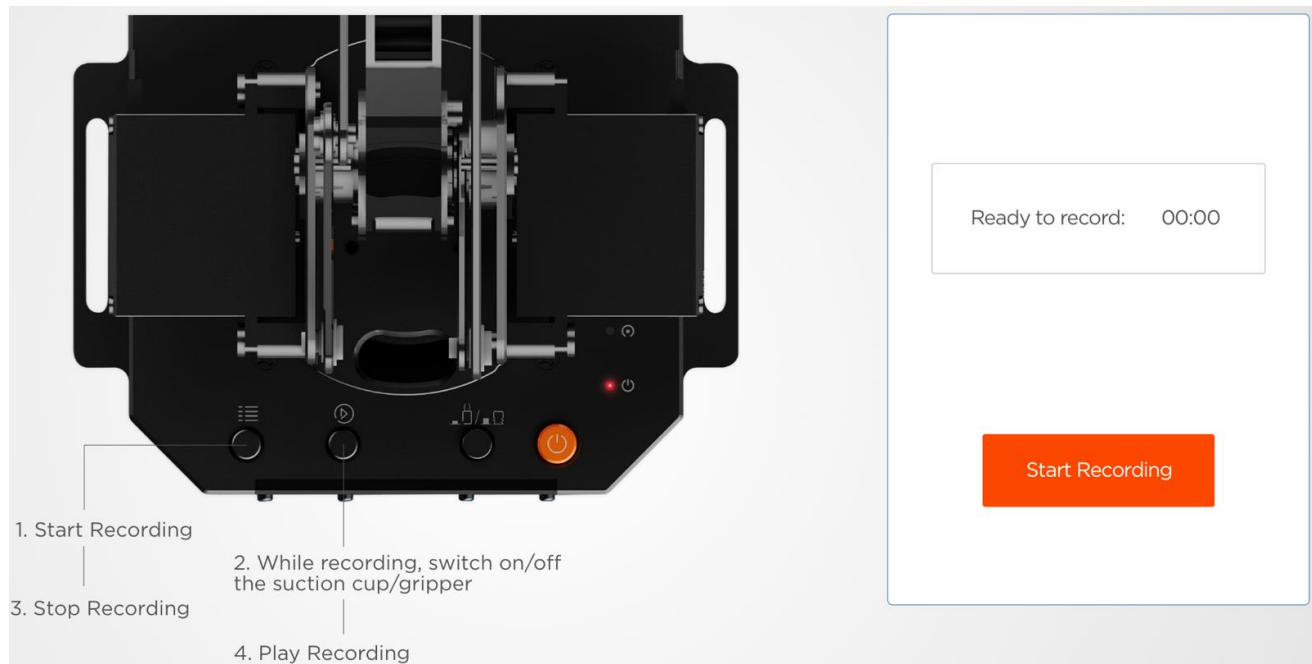

2) Save your recording

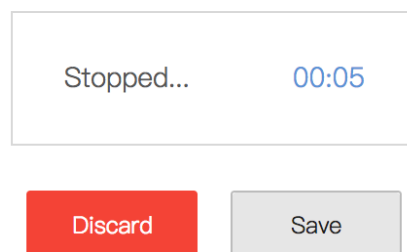

3) Replay the recording in different speed and times

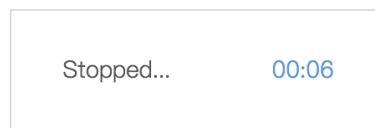

Discard

Save

Speed 1x

Times 1

Loop

Play

What makes “Teach & Play” different from “Offline Learning Mode”?

- 1) No time limit while “teaching” with uArm Studio.
- 2) You may save, export your recordings and import recordings made by others.
- 3) You may apply your recording in Blockly (visual programming interface, which is explained up next).

6.Blockly: Visual Programming

What is Blockly?

Blockly in uArm Studio is a visual programming interface specially designed for controlling uArm.

Getting Started

Three “missions” are prepared to get you through Blockly quickly.

Please try them out!

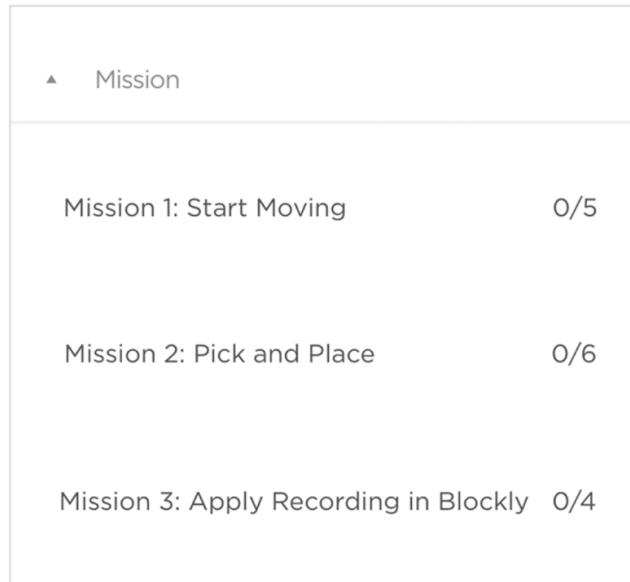

What can you do with Blockly?

- 1) Control uArm’s basic movements

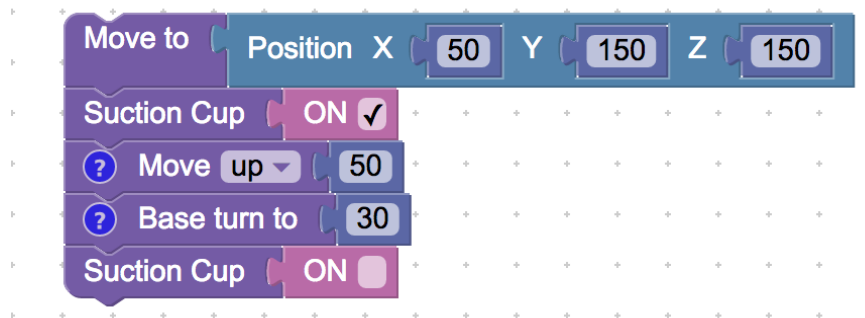

- 2) Change events (i.e. how you trigger commands)

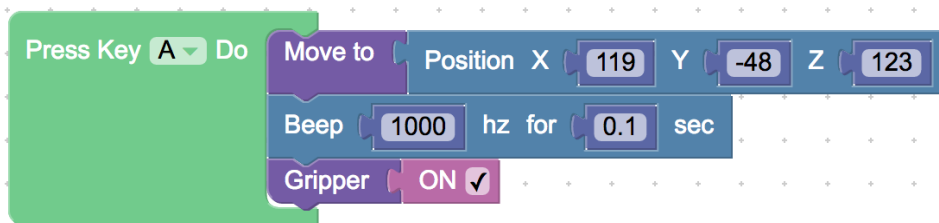

- 3) Apply recorded movements

```

When face is recognised
  Play Recording pick and place Speed: 1x
  Move to Position X 119 Y -49 Z 123
  
```

4) Dig deeper into programming (functions, variables, etc.)

```

raise up with:
  x 5

to raise up with: x
  set height to 100
  repeat x times
  do
    Move to Position X 120 Y -48 Z height
    Wait 0.5
    change height by 100
  return
  
```

uArm Community

[UFACTORY Official Forum](#)

[uArm User Facebook Group](#)

[uArm Technical Support](#)

Release Note

Version	Note	
1.0.7	Modify several steps of 3D printing and fix the misunderstanding Add the laser mode command G1	Tony
1.0.8	Add more details about OpenMV Add the note of laser focusing Add the caution of installing base extension Add the caution of user defined button	Tony
1.0.9	Modify the steps of laser focusing and grove installing	Tony
1.0.10	Add more details to OpenMV tutorial Add details to offline learning modess Add M2500 command in command list	Tony
1.0.11	Modify the OpenMV instructions Add more Gcode commands	Tony
1.0.12	Add the details of installing the tube in 3D printing mode	Tony
1.0.13	Add new picture of working range	Tony
1.0.14	Add cautions in 3D printing	Tony
1.0.15	Modify several commands of Gcode Redesign the layout of this guide	David ChengHan